

## Description

DC Alloy Thermal-Link is defined as a Non-Resettable protective device functioning one time only. It is widely used in electrical equipment and electric vehicle. Normally, thermal element and fuse is jointed in parallel to the two electrode leads. Under abnormal conditions, when the temp. reaches to the fusing temp. of Thermal-Link, the thermal element melts and quickly retracts to the two electrode lead ends with the aid of the flux, then fuse melts to disconnect the circuit completely.

## Structure Diagrams

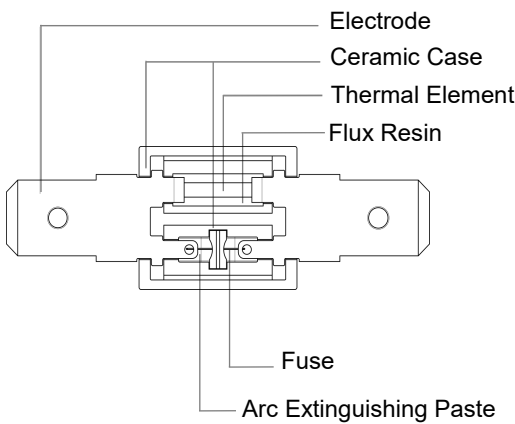

## Product Schematic

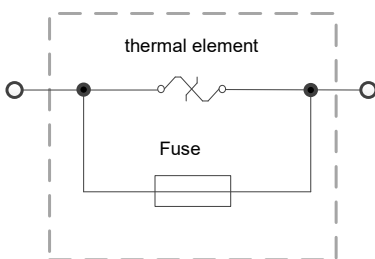

## Features

- 0 to 850 VDC Operating Voltage
- High Accuracy of Functioning Temp.
- Ceramic Case
- Non-Resettable
- RoHS & REACH Compliant





## Applications

- Battery Cooling Systems
- Precharged Resistors
- Automotive Air-Conditioners
- Heaters

## Customization

- Rated Functioning Temp.
- The Shape of Electrode Leads

## Agency Approvals

Agency Mark	Standards	File No.
	UL60691	Ongoing
	CAN-CSA-E60691	Ongoing
	EN60691	Ongoing
	EN60691	Ongoing
	GB9816	Ongoing

**Marking**

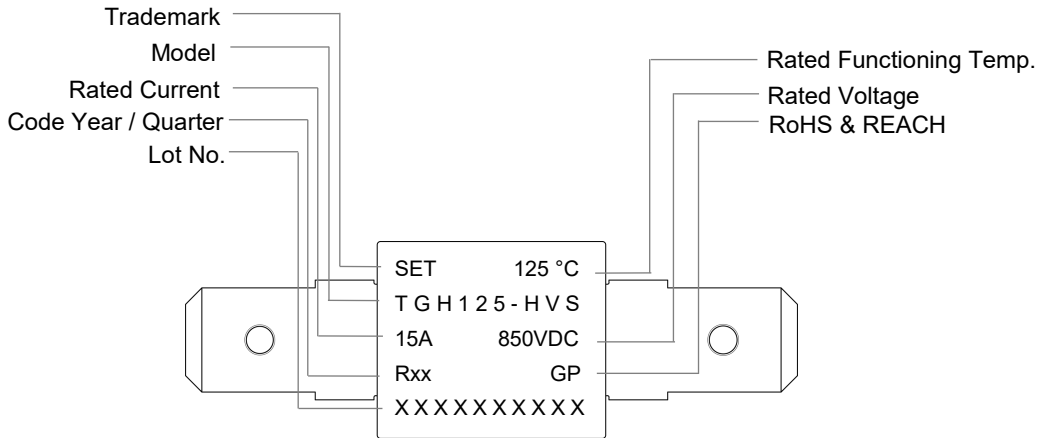

**Part Numbering System**

DC-ATCO - TGH125 - HV S

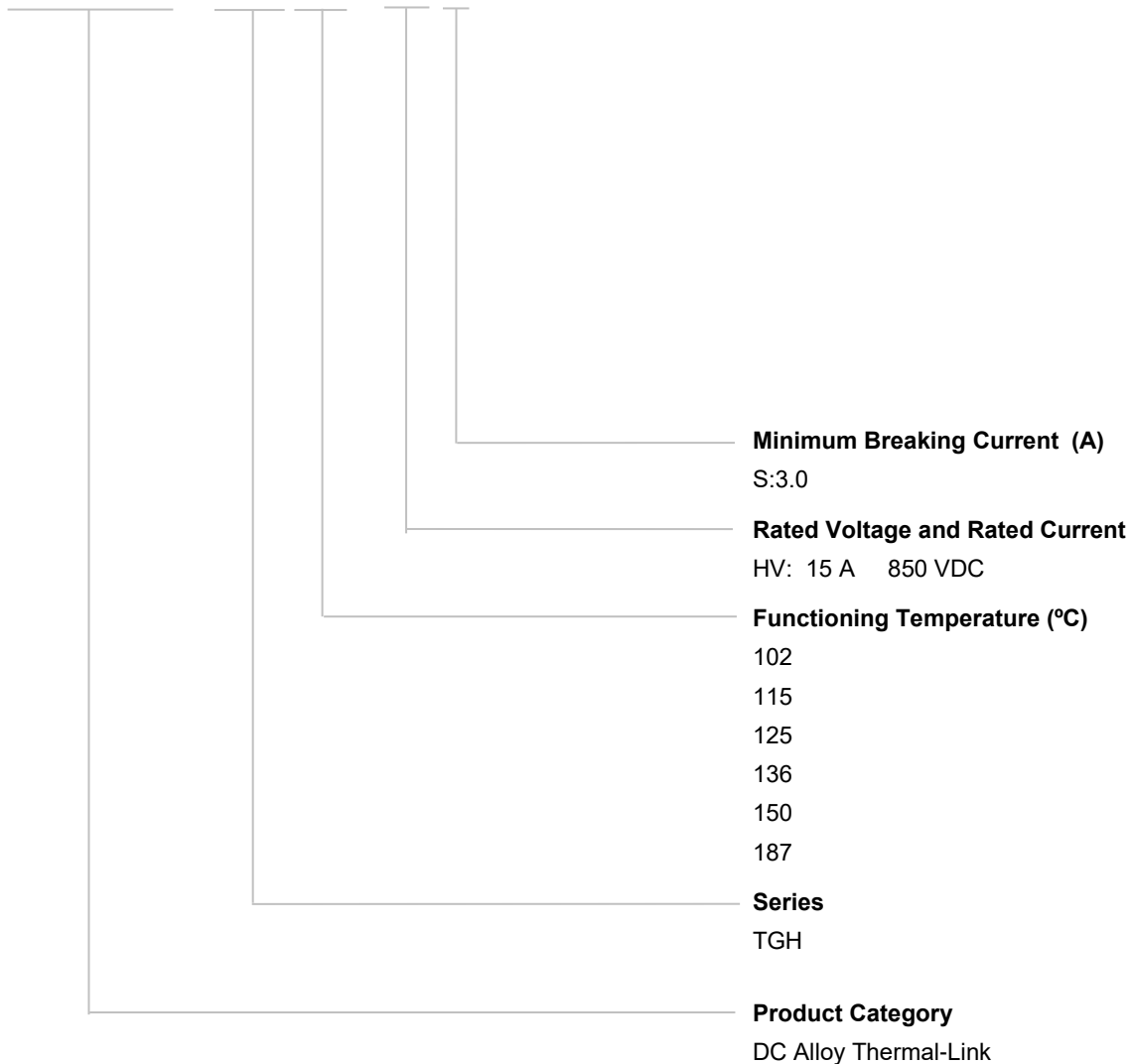

## Glossary

Item	Description
<b>TCO</b>	<b>Thermal-Link</b> A non-resettable device incorporating a THERMAL ELEMENT which will open a circuit once only when exposed for a sufficient length of time to a temperature in excess of that for which it has been designed.
<b>ATCO</b>	<b>Alloy Thermal-Link</b> Alloy Type Thermal-Link, Alloy is the thermal element.
<b>DC-ATCO</b>	<b>DC-Alloy Thermal-Link</b> Direct Current Alloy Thermal-Link.
<b><math>T_f</math></b>	<b>Rated Functioning Temp.</b> The temperature of the Thermal-Link which causes it to change the state of conductivity with a detection current up to 10 mA as the only load. Tolerance: $T_f +0 / -10$ °C (GB 9816, EN 60691, K60691). Tolerance: $T_f \pm 7$ °C (J60691).
<b>Fusing Temp. with Load</b>	The temperature of the Thermal-Link with Rated Current which causes it to change its state of conductivity is measured with silicone oil bath in which the temperature is increased at the rate of 0.5 °C to 1 °C / minute, with a detection current up to 10 mA as the only load.
<b><math>T_h</math></b>	<b>Holding Temp.</b> The Maximum temperature at which a Thermal-Link will not change its state of conductivity when conducting rated current for 168 hours.
<b><math>T_m</math></b>	<b>Maximum Temp. Limit</b> The temperature of the Thermal-Link stated by the manufacturer, up to which the mechanical and electrical properties of the Thermal-Link having changed its state of conductivity, will not be impaired for a given time.
<b><math>I_{min}</math></b>	<b>Minimum Breaking Current</b> The minimum current that Fuse requires after the Alloy of Thermal-Link opens in the circuit.
<b><math>I_r</math></b>	<b>Rated Current</b> The current used to classify a Thermal-Link, which is the maximum current that Thermal-Link allows to carry and is able to cut off the circuit safely.
<b><math>U_r</math></b>	<b>Rated Voltage</b> The voltage used to classify a Thermal-Link, which is the maximum voltage that Thermal-Link allows to carry and is able to cut off the circuit safely.



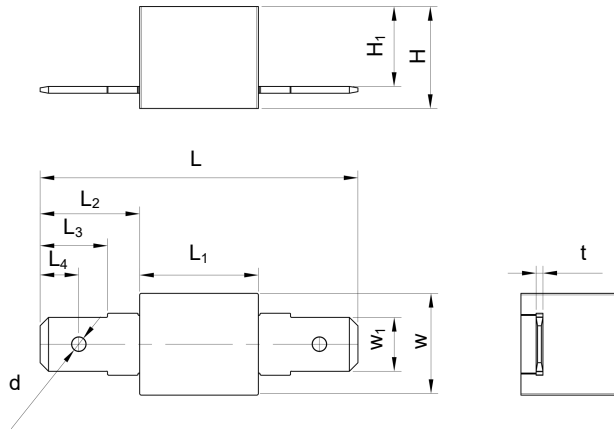

**Dimensions (mm)**



L	L <sub>1</sub>	L <sub>2</sub>	L <sub>3</sub>	L <sub>4</sub>	W	W <sub>1</sub>	H	H <sub>1</sub>	t	D
37.5 ± 2.0	14.0 ± 1.0	11.75 ± 0.30	7.95 ± 0.30	4.55 ± 0.2	12.0 ± 1.0	6.35 ± 0.20	12.0 <sup>+0.8</sup> <sub>-0.8</sub>	9.4 <sup>+1.0</sup> <sub>-0.6</sub>	0.80 ± 0.05	1.65±0.20

**Specifications**

For Automotive Application: Battery Cooling System, Pre-charged Resistor, Automotive Air Conditioning

Model	$T_f$	Fusing Temp. with Load	$T_h$	$T_m$	$I_{min}$	$I_r$	$U_r$						RoHS REACH
	(°C)	(°C)	(°C)	(°C)	(A)	(A)	(V)	UL	CUL	TUV	VDE	CCC	
TGH102-HVS	102	92 ± 3	63	250	3	15	DC 850						●
TGH115-HVS	115	107 ± 3	65	250	3	15	DC 850						●
TGH125-HVS	125	107 ± 3	75	250	3	15	DC 850						●
TGH130-HVS	130	108 ± 3	80	250	3	15	DC 850						●
TGH136-HVS	136	109 ± 3	80	250	3	15	DC 850						●
TGH150-HVS	150	135 ± 3	105	250	3	15	DC 850						●
TGH187-HVS	187	180 ± 3	155	250	3	15	DC 850						●

### Temp.-Time Curve

The functioning temperature time curve of Alloy Thermal-Link in different Temp. oil bath. (This curve is for reference only)

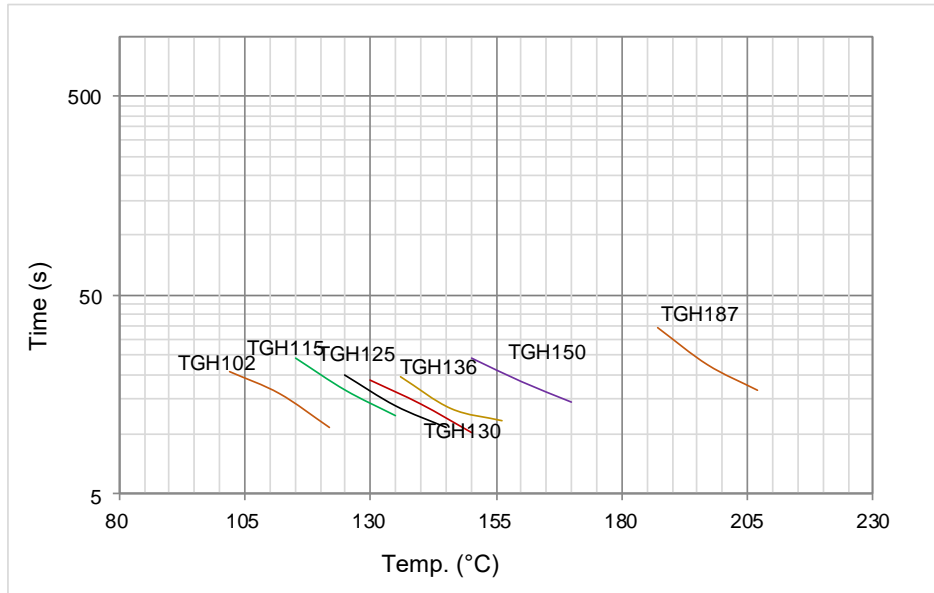

### Current-Time Curve

This is an illustrated curve, describing the opening time at Multi-times rated current in the condition of the room Temp. 25 °C. (This curve is for reference only)

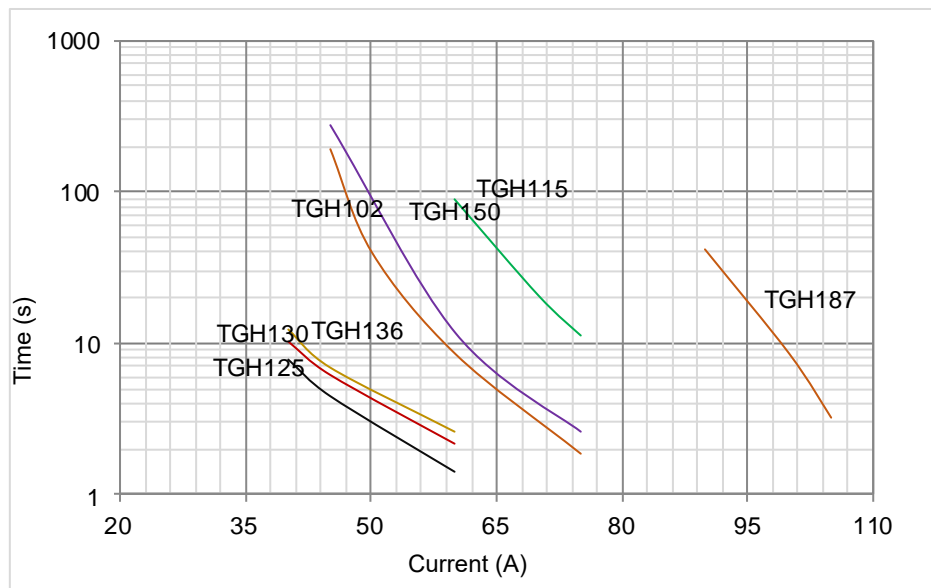

ATCO

ATCO



# ATTENTION

## Usage

1. When atmosphere pressure is from 80 kPa to 106 kPa, the related altitude shall be from +2000 m to - 500 m.
2. Operating voltage less than rated voltage of DC-ATCO, operating current less than rated current of DC-ATCO.
3. Do not touch the DC-ATCO body or lead wires directly when power is on, to avoid burn or electric shock.

## Replace

DC-ATCO is a non-repairable product. For safety sake, it shall be replaced by an equivalent DC-ATCO from the same manufacturer, and mounted in the same way.

## Storage

Do not store the DC-ATCO at the high temp., high humidity or corrosive gas environment. The product shall be stored at  $25 \pm 5^\circ\text{C}$  and  $\leq 70\%$  RH, avoid direct sunlight and shall use them up within 1 year after receiving the goods.

## Installation

### Make Sure the Installation Position be close to the heat source.

1. It is recommended that a dummy DC-ATCO with inbuilt thermo-couple shall be used to determine the proper temperature.
2. The terminal product should be tested to ensure that potential abnormal conditions do not cause ambient temp. to exceed the  $T_m$  of the DC-ATCO.
3. Mount the DC-ATCO at the location where Temp. rises evenly.

### Installation position of mechanical performance requirements.

1. Ensure that the electrode lead is long enough, and avoid actions such as press, tensile or twist.
2. The seal or body of DC-ATCO must not be damaged, burned or over heated.

**Packaging Information**

Item	Tray	PE Bag	Carton
Dimensions (mm)	295 x 217 x 16	295 x 217 x 60	455 x 315 x 285
Quantity (PCS)	70	280	2240
Gross Weight (kg):			20 ± 10%

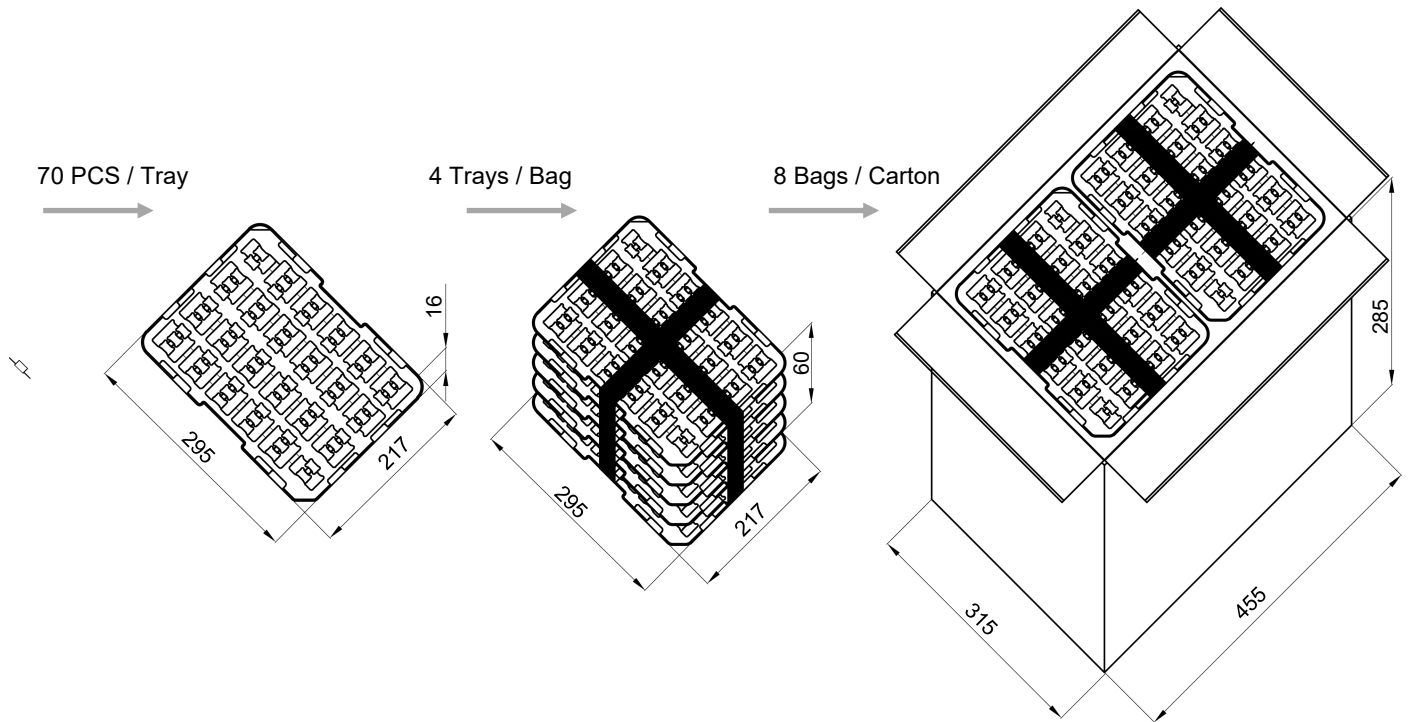

ATCO

ATCO