

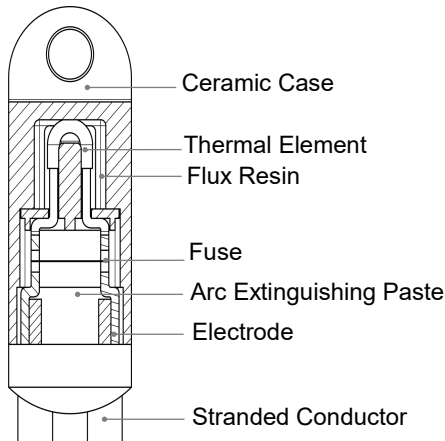

Description

DC-Alloy Thermal-Link / DC-Alloy Thermal Cutoff (DC-ATCO) is defined as a non-resettable protective device functioning one time only. It is widely used in electrical equipment and electric vehicle DC-ATCO is mainly consist of Thermal Element, Flux Resin, Case, Sealant and Lead Wires. Normally, thermal element is jointed to the two lead wires. Under abnormal conditions, when the temp. reaches to the fusing temp. of DC-ATCO, the thermal element melts and quickly retracts to the two lead wire ends with the aid of the flux resin and disconnects the circuit completely.

Structure Diagrams



Product Schematic

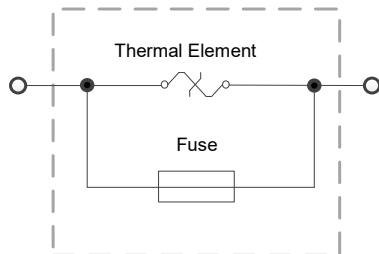

Features

- 0 to 600 VDC Operating Voltage
- High Accuracy of Functioning Temp.
- Ceramic Case
- Non-Resettable
- RoHS & REACH Compliant

Applications

- Battery Cooling Systems
- Precharged Resistors
- Automotive Air-Conditioners
- Heaters

Customization

- Rated Functioning Temp.
- The Shape of Stranded Conductor

Agency Approvals

Agency Mark	Standards	File No.
	UL60691	Ongoing
	CAN-CSA-E60691	Ongoing
	EN60691	Ongoing
	EN60691	Ongoing
	GB9816	Ongoing

Marking

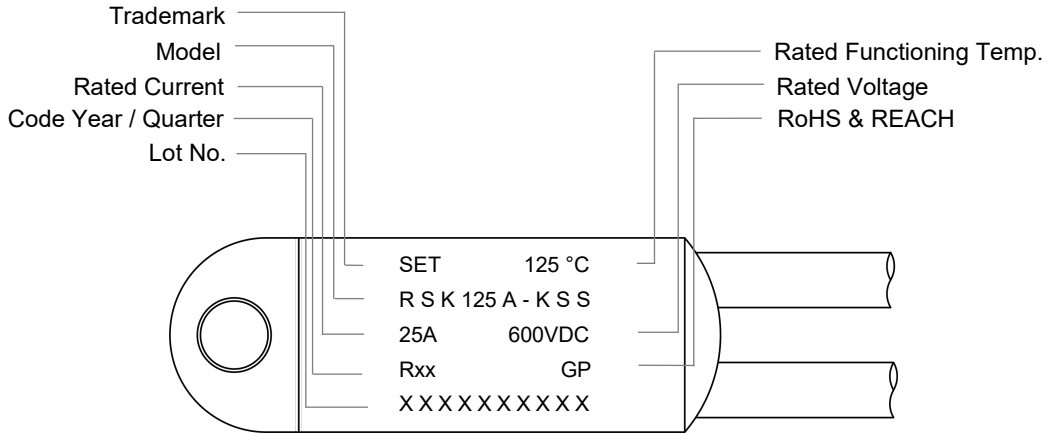

ATCO

ATCO

Part Numbering System

DC-ATCO - RSK125A - KS S

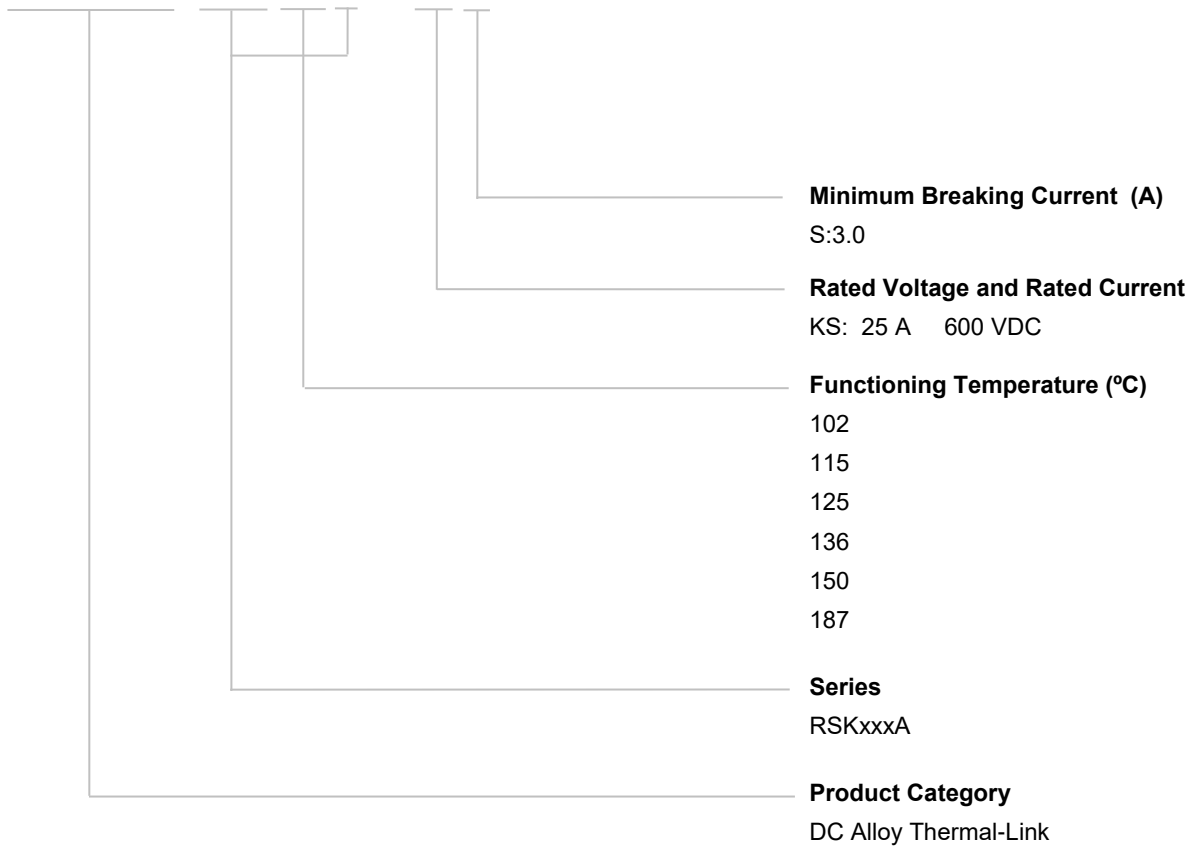

Glossary

Item	Description
TCO	<p>Thermal-Link</p> <p>A non-resettable device incorporating a THERMAL ELEMENT which will open a circuit once only when exposed for a sufficient length of time to a temperature in excess of that for which it has been designed.</p>
ATCO	<p>Alloy Thermal-Link</p> <p>Alloy Type Thermal-Link, Alloy is the thermal element.</p>
DC-ATCO	<p>DC-Alloy Thermal-Link</p> <p>Direct Current Alloy Thermal-Link.</p>
T_f	<p>Rated Functioning Temp.</p> <p>The temperature of the Thermal-Link which causes it to change the state of conductivity with a detection current up to 10 mA as the only load.</p> <p>Tolerance: $T_f +0 / -10$ °C (GB 9816, EN 60691, K60691).</p> <p>Tolerance: $T_f \pm 7$ °C (J60691).</p>
Fusing Temp. with Load	<p>The temperature of the Thermal-Link with Rated Current which causes it to change its state of conductivity is measured with silicone oil bath in which the temperature is increased at the rate of 0.5 °C to 1 °C / minute, with a detection current up to 10 mA as the only load.</p>
T_h	<p>Holding Temp.</p> <p>The Maximum temperature at which a Thermal-Link will not change its state of conductivity when conducting rated current for 168 hours.</p>
T_m	<p>Maximum Temp. Limit</p> <p>The temperature of the Thermal-Link stated by the manufacturer, up to which the mechanical and electrical properties of the Thermal-Link having changed its state of conductivity, will not be impaired for a given time.</p>
I_{min}	<p>Minimum Breaking Current</p> <p>The minimum current that Fuse requires after the Alloy of Thermal-Link opens in the circuit.</p>
I_r	<p>Rated Current</p> <p>The current used to classify a Thermal-Link, which is the maximum current that Thermal-Link allows to carry and is able to cut off the circuit safely.</p>
U_r	<p>Rated Voltage</p> <p>The voltage used to classify a Thermal-Link, which is the maximum voltage that Thermal-Link allows to carry and is able to cut off the circuit safely.</p>

Dimensions (mm)

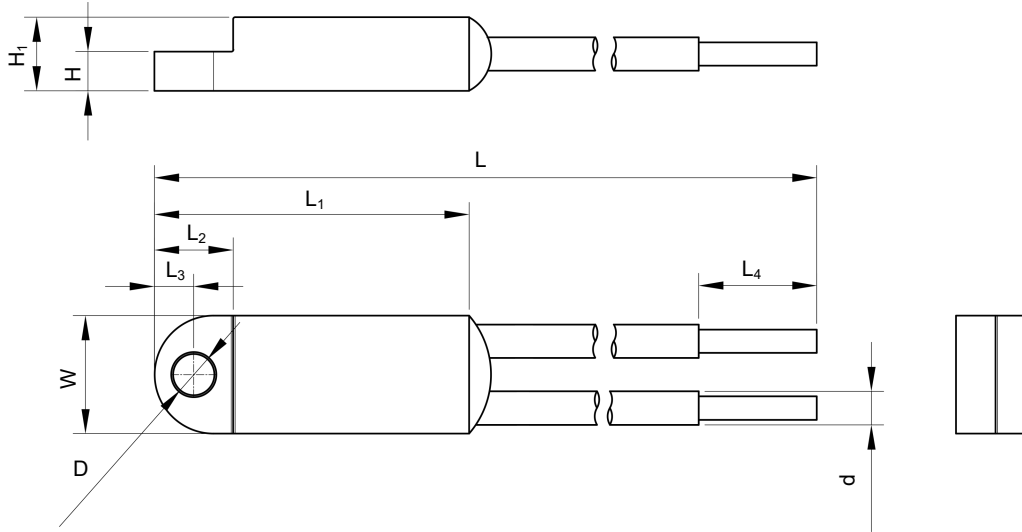

L	L ₁	L ₂	L ₃	L ₄	W	H	H ₁	D	d
132.0 ± 5.0	32.0 ± 1.0	8.00 ± 0.5	4.0 ± 0.5	10.0 ± 1.0	12.0 ± 1.0	4.0 ± 0.5	7.5 ± 1.0	4.2 ± 0.5	AWG12

Specifications

Model	T_f	Fusing Temp. with Load	T_h	T_m	I_{min}	I_r	U_r						RoHS REACH	
	(°C)	(°C)	(°C)	(°C)	(A)	(A)	(V)	UL	CUL	TUV	VDE	CCC		
RSK102A-KSS	102	82 ± 3	55	250	3.0	25	DC 600							●
RSK115A-KSS	115	95 ± 3	65		3.0	25	DC 600							●
RSK125A-KSS	125	105 ± 3	70		3.0	25	DC 600							●
RSK136A-KSS	135	116 ± 3	80		3.0	25	DC 600							●
RSK150A-KSS	150	130 ± 3	95		3.0	25	DC 600							●
RSK187A-KSS	187	167 ± 3	140		3.0	25	DC 600							●

Temp.-Time Curve

The functioning temperature time curve of Alloy Thermal-Link in different Temp. oil bath. (This curve is for reference only)

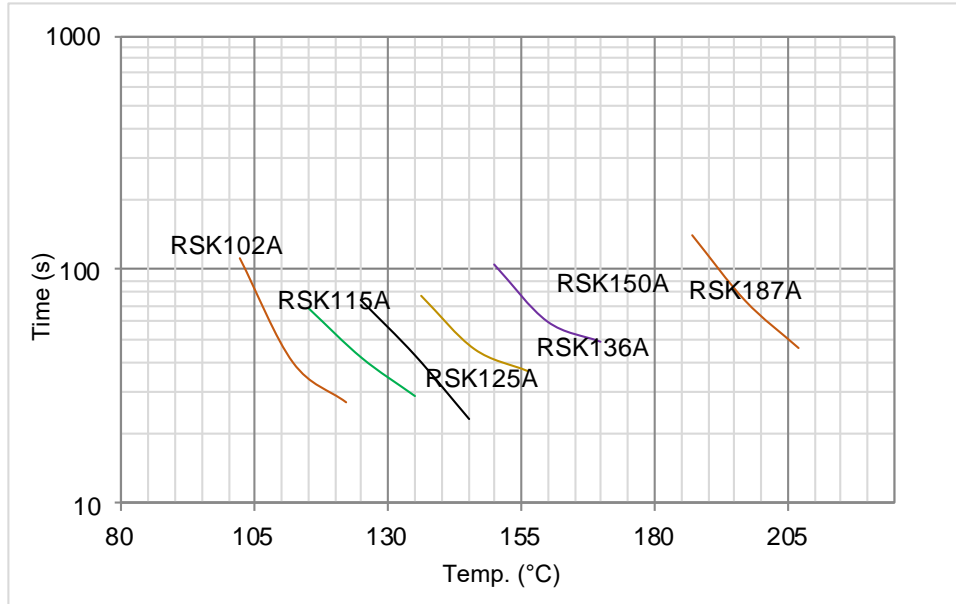

Current-Time Curve

This is an illustrated curve, describing the opening time at Multi-times rated current in the condition of the room Temp. 25 °C. (This curve is for reference only)

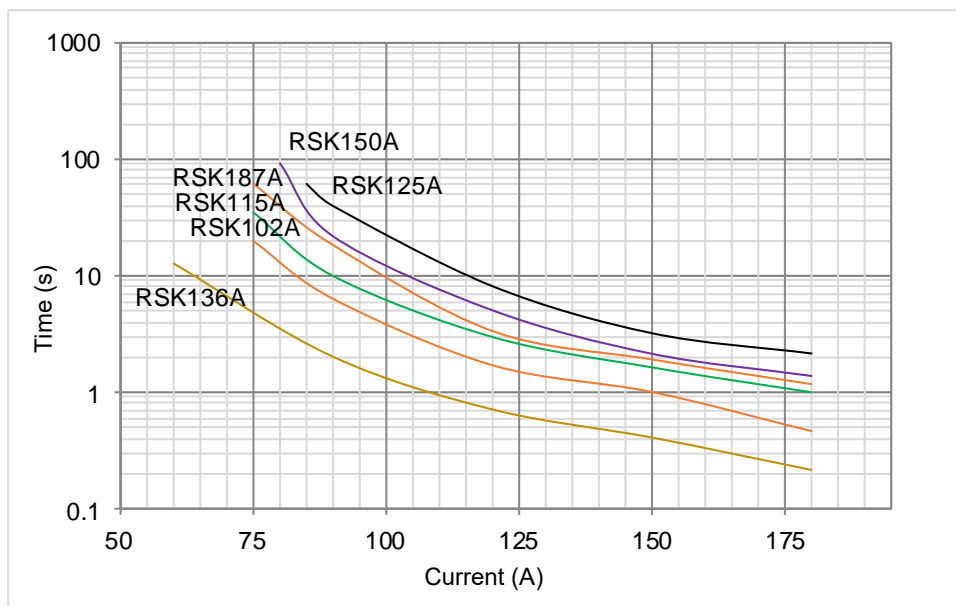



ATTENTION

Usage

1. When atmosphere pressure is from 80 kPa to 106 kPa, the related altitude shall be from +2000 m to - 500 m.
2. Operating voltage less than rated voltage of DC-ATCO, operating current less than rated current of DC-ATCO.
3. Do not touch the DC-ATCO body or lead wires directly when power is on, to avoid burn or electric shock.

Replacement

DC-ATCO is a non-repairable product. For safety sake, it shall be replaced by an equivalent DC-ATCO from the same manufacturer, and mounted in the same way.

Storage

Do not store the DC-ATCO at the high temp., high humidity or corrosive gas environment. The product shall be stored at 25 ± 5 °C and $\leq 70\%$ RH, avoid direct sunlight and shall use them up within 1 year after receiving the goods.

Installation

Make Sure the Temp. of Installation Position

1. It is recommended that a dummy DC-ATCO with inbuilt thermo-couple shall be used to determine the proper temp.
2. The terminal product should be tested to ensure that potential abnormal conditions do not cause ambient temp. to exceed the T_m of the DC-ATCO.
3. Mount the DC-ATCO at the location where Temp. rises evenly.

Installation position of mechanical performance requirements.

1. Ensure that the electrode lead is long enough, and avoid actions such as press, tensile or twist.
2. The seal or body of DC-ATCO must not be damaged, burned or over heated.

Mechanical Connection

Riveting

Suitable for the stranded conductor diameter (d) of DC-ATCO ≥ 1.2 mm.

1. Choose small resistivity riveting material and be riveted.
2. A flexible lead or lead with low resistance should be used to rivet the DC-ATCO.
3. Contact resistance should be minimal, Large contact resistance will lead to higher temp., DC-ATCO Functioning in advance.

Soldering

Hand-Soldering

1. Soldering should be carried out according to Table RSKXXXA-1.
2. The thermal element of DC-ATCO is thermal element with low melting point, which is jointed with DC-ATCO electrode lead. Improper soldering operation (too high soldering temp., too long soldering time etc.) may transfer more heat to the thermal element and DC-ATCO may open in advance.
3. When soldering conditions are more severe than those listed in Table RSKXXXA-1, a heat sink fixture should be used between soldering point and DC-ATCO body.
4. When soldering, please do not pull / push or twist DC-ATCO body or stranded conductor.
5. After soldering, let it naturally cool for longer than 20 sec. During cooling, never move the DC-ATCO body or stranded conductor.

TABLE RSKxxxA-1 Hand-Soldering Time

Rated Functioning Temp.	Max. Allowable Soldering Time for Different Stranded Conductor Length (Fig.RSKxxxA-1)						Max. Soldering Temp.
	L ₅ Length	Time	L ₅ Length	Time	L ₅ Length	Time	
(°C)	(mm)	(s)	(mm)	(s)	(mm)	(s)	(°C)
76 ~ 101	10	1 ^a	20	2	30	3	400
102 ~ 115	10	1 ^a	20	2	30	3	
116 ~ 135	10	1 ^a	20	3	30	5	
136 ~ 150	10	3	20	5	30	5	
151 ~ 230	10	4	20	6	30	7	

Note:

a: Auxiliary Heat Sink Fixture is Required to Avoid DC-ATCO Cutting off Unexpectedly.

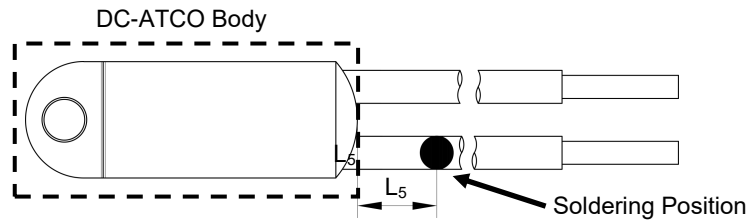

FIGURE RSKxxxA-1

Stranded Conductor Forming

1. If stranded conductor has to be bent, please pay attention to the distance between body and bending point. Refer to the following table.
2. When bending stranded conductor, please use pincher or similar tools to fix the product as shown in Fig. RSKxxxA-2, to avoid damaging the product. The distance L_6 between the bending position and DC-ATCO sealing end should refer to Table RSKxxxA-2.
3. During forming and mounting, stranded conductor should not be cut, nicked, bent sharply, to avoid breaking the product.
4. Tangential forces on the stranded conductor must be avoided (i.e. pushing or pulling on the stranded conductor at angle to DC-ATCO body) as such forces may damage the seal of DC-ATCO.
5. Bending radius R : $\geq 15d$, as shown in Figure 2.

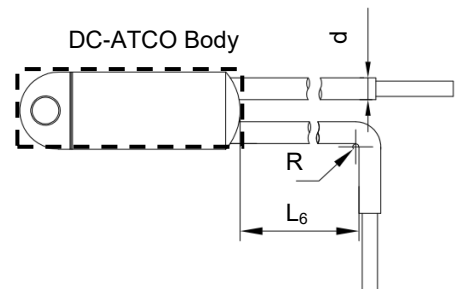

FIGURE RSKxxxA-2

TABLE RSKxxxA-2 Distance between Body and Bending Point

d (mm)	≤ 1.0	1.0 - 1.2	> 1.2
L_6 (mm)	≥ 3	≥ 5	≥ 10

Packaging Information

Item	Tray	Box	Carton
Dimensions (mm)	422 x 122 x 15.3	429 x 85 x 131	455 x 315 x 285
Quantity (PCS)	20	100	600
Gross Weight (kg):			20 ± 10%

ATCO

ATCO

