

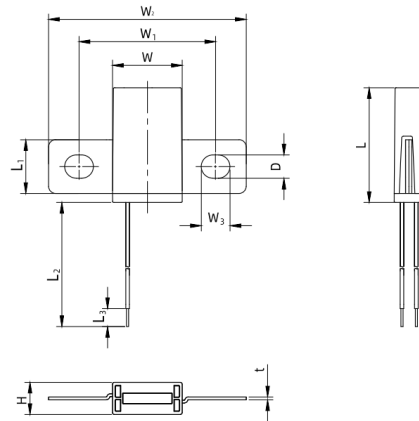

Dimensions (mm)



W	W ₁	W ₂	W ₃	L	L ₁	L ₂	L ₃	D	t	H
19.4 ± 0.2	38.0 ± 0.5	55.0 ± 1.0	8.0 ± 0.1	32.0 ± 0.5	15.0 ± 0.1	70.0 ± 5.0	5.0 ± 1.0	6.5 ± 0.1	0.8 ± 0.1	9.0 ± 0.2

Structure Diagrams

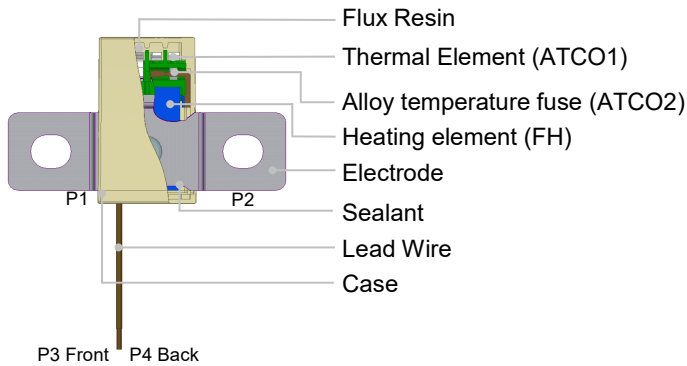

- P1 ~ P4 Port

Features

- Low Impedance, Low Power Consumption
- MC Controlled Fusing Time ≤ 60 s
- Non-Resettable
- Active Control
- Over Temp. Protection
- Self-Control Protection
- RoHS & REACH Compliant

Product Schematic

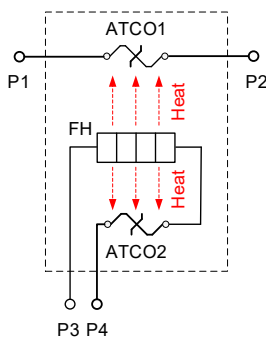



- P1 ~ P2 Main Circuit (MC)
- P3 ~ P4 Control Circuit (CC)

Application

- Electric Motorcycle, Electric Golf Cart
- Electric Yacht, Household Energy Storage
- Base Station Power Supply, Battery

Agency Approvals

Agency Mark	Standards	File No.
	UL60691	E214712
	CAN-CSA-E60691	E214712

Part Number System

iTCO - TKS150 - R 7 N - S J Z

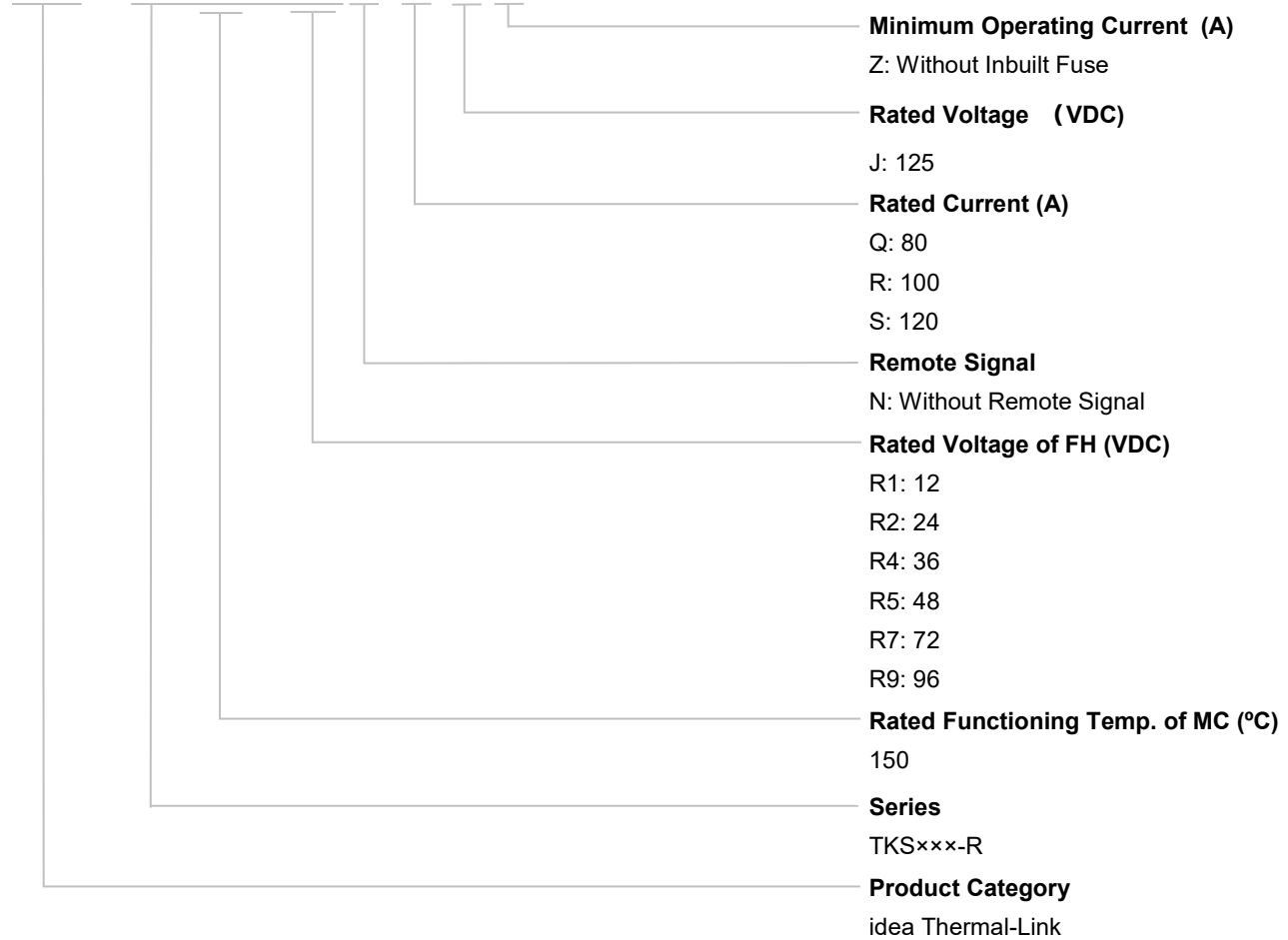

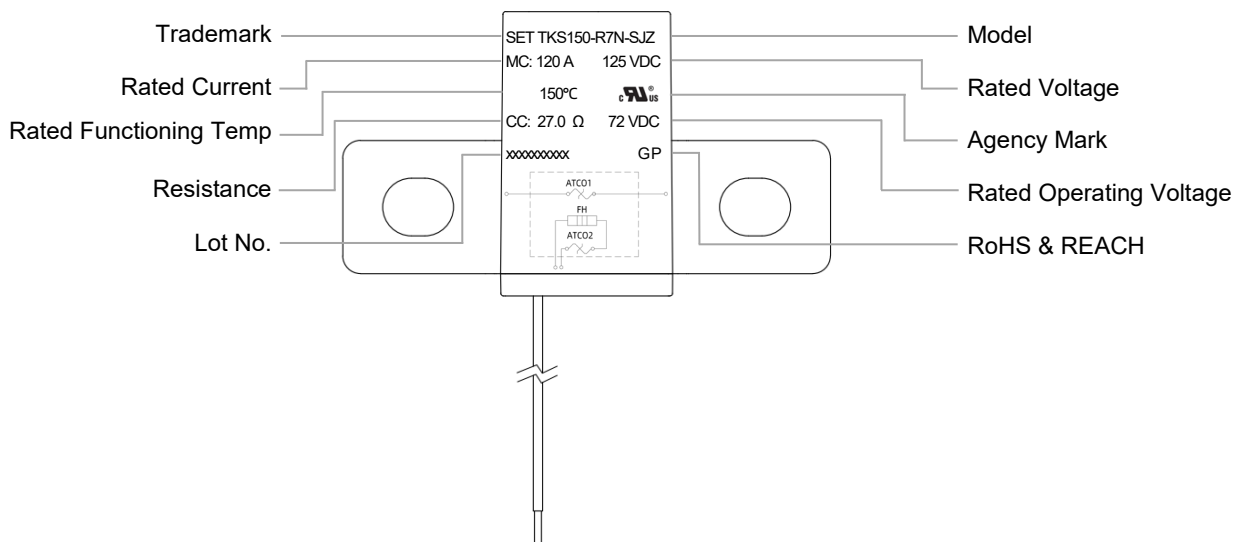

Marking



Glossary

Item	Description
iTCO	idea Thermal-Link Protector that can fuse itself after receiving control signal.
TCO	Thermal-Link A non-resettable device incorporating a thermal element which will open a circuit once only when exposed for a sufficient length of time to a temp. in excess of that for which it has been designed.
ATCO	Alloy type Thermal-Link Alloy type Thermal-Link, Alloy is thermal element.
FH	Feed Heater Electric appliances that use electric energy to achieve heating effect.
MC	Main Circuit All conductive components used in switching devices for closing or disconnecting circuits in a circuit.
CC	Control Circuit In addition to the main circuit, all conductive parts of the switching apparatus used in the access circuit as the closing operation and / or opening operation of the switching apparatus.
I_r	Rated Current The current used to classify an iTCO, which is the Maximum current that iTCO allows to carry and is able to cut off the circuit safely.
U_r	Rated Voltage The voltage used to classify an iTCO, which is the Maximum voltage that iTCO allows to carry and is able to cut off the circuit safely.
T_f	Rated Functioning Temp. The temperature of the Thermal-Link which causes it to change the state of conductivity with a detection current up to 10 mA as the only load. Tolerance: $T_f 0 / -10$ °C (GB 9816, EN 60691, K60691). Tolerance: $T_f \pm 7$ °C (J60691).
Fusing Temp.	Fusing Temp. The temp. of the iTCO which causes it to change its state of conductivity is measured with silicone oil bath in which the temp. is increased at the rate of (0.5 to 1) °C /minutes, with a detection current less than 10 mA as the only load.
T_h	Holding Temp. The Maximum temp. at which iTCO will not change its state of conductivity when conducting rated current for 168 h.
T_m	Maximum Temp. Limit The temp. of the iTCO stated by the manufacturer, up to which the mechanical and electrical properties of the iTCO having changed its state of conductivity, will not be impaired for a given time.

Specifications

Model	Main Circuit Specifications						Control Circuit Specifications		Fusing Time		Agency Mark	
	T_f	Fusing Temp.	T_h	T_m	I_r	U_r	Rated Operating Voltage U_r	Cold Resistance	t_{mc} (P1 ~ P2)	t_{cc} (P3 ~ P4)		
	(°C)	(°C)	(°C)	(°C)	(A)	(VDC)	(VDC)	(Ω)	(s)	(s)	UL	cUL
TKS150-R1N-QJZ	150	146 ± 3	85	180	80	125	12	0.8 ± 0.2	≤ 60	$t_{mc} + (0\sim30)$	●	●
TKS150-R2N-QJZ	150	146 ± 3	85	180	80	125	24	2.7 ± 1.0	≤ 60	$t_{mc} + (0\sim30)$	●	●
TKS150-R4N-QJZ	150	146 ± 3	85	180	80	125	36	7.0 ± 2.0	≤ 60	$t_{mc} + (0\sim30)$	●	●
TKS150-R5N-QJZ	150	146 ± 3	85	180	80	125	48	12.0 ± 2.0	≤ 60	$t_{mc} + (0\sim30)$	●	●
TKS150-R7N-QJZ	150	146 ± 3	85	180	80	125	72	27.0 ± 5.0	≤ 60	$t_{mc} + (0\sim30)$	●	●
TKS150-R9N-QJZ	150	146 ± 3	85	180	80	125	96	40.0 ± 8.0	≤ 60	$t_{mc} + (0\sim30)$	●	●
TKS150-R1N-RJZ	150	146 ± 3	85	180	100	125	12	0.8 ± 0.2	≤ 60	$t_{mc} + (0\sim30)$	●	●
TKS150-R2N-RJZ	150	146 ± 3	85	180	100	125	24	2.7 ± 1.0	≤ 60	$t_{mc} + (0\sim30)$	●	●
TKS150-R4N-RJZ	150	146 ± 3	85	180	100	125	36	7.0 ± 2.0	≤ 60	$t_{mc} + (0\sim30)$	●	●
TKS150-R5N-RJZ	150	146 ± 3	85	180	100	125	48	12.0 ± 2.0	≤ 60	$t_{mc} + (0\sim30)$	●	●
TKS150-R7N-RJZ	150	146 ± 3	85	180	100	125	72	27.0 ± 5.0	≤ 60	$t_{mc} + (0\sim30)$	●	●
TKS150-R9N-RJZ	150	146 ± 3	85	180	100	125	96	40.0 ± 8.0	≤ 60	$t_{mc} + (0\sim30)$	●	●
TKS150-R1N-SJZ	150	146 ± 3	85	180	120	125	12	0.8 ± 0.2	≤ 60	$t_{mc} + (0\sim30)$	●	●
TKS150-R2N-SJZ	150	146 ± 3	85	180	120	125	24	2.7 ± 1.0	≤ 60	$t_{mc} + (0\sim30)$	●	●
TKS150-R4N-SJZ	150	146 ± 3	85	180	120	125	36	7.0 ± 2.0	≤ 60	$t_{mc} + (0\sim30)$	●	●
TKS150-R5N-SJZ	150	146 ± 3	85	180	120	125	48	12.0 ± 2.0	≤ 60	$t_{mc} + (0\sim30)$	●	●
TKS150-R7N-SJZ	150	146 ± 3	85	180	120	125	72	27.0 ± 5.0	≤ 60	$t_{mc} + (0\sim30)$	●	●
TKS150-R9N-SJZ	150	146 ± 3	85	180	120	125	96	40.0 ± 8.0	≤ 60	$t_{mc} + (0\sim30)$	●	●

Product Current-Time Curve (Reference)

The Current-Time Curve shows functioning time at multi-times rated current at room temperature (25 ± 2) °C.

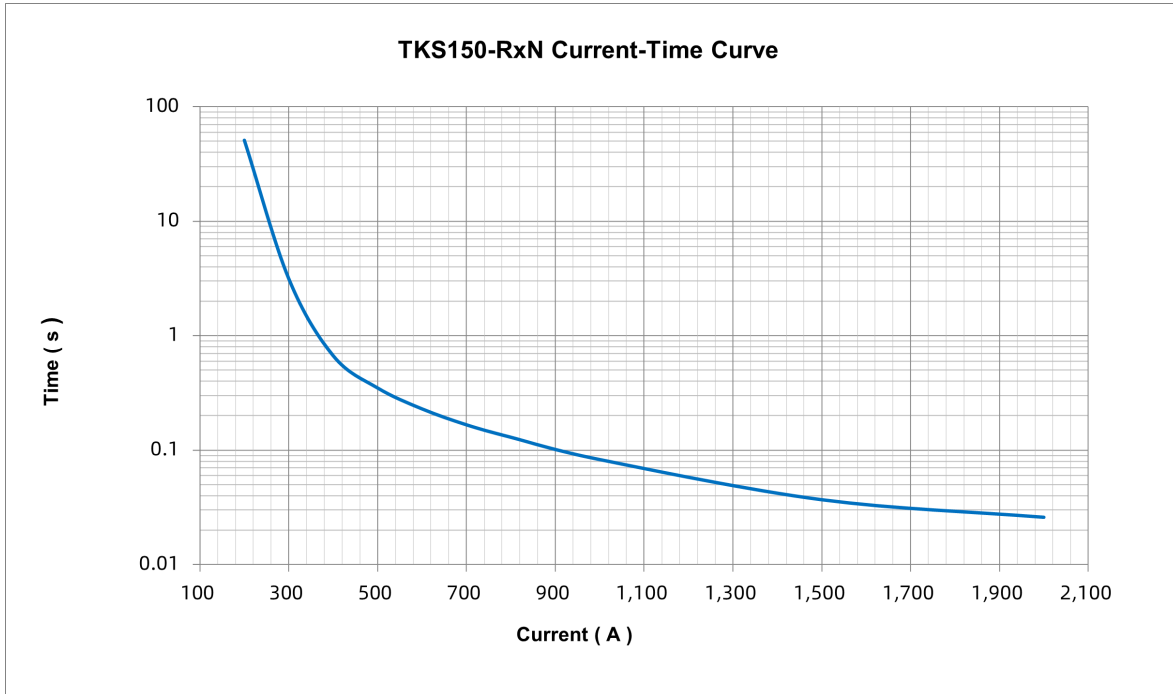

Packing Information

Item	Tray	Bag	Carton
Dimensions (mm)	345 × 250 × 14	345 × 250 × 55	370 × 275 × 410
Quantity (PCS)	12	60	420
Gross Weight (kg)			11.3 ± 10 %

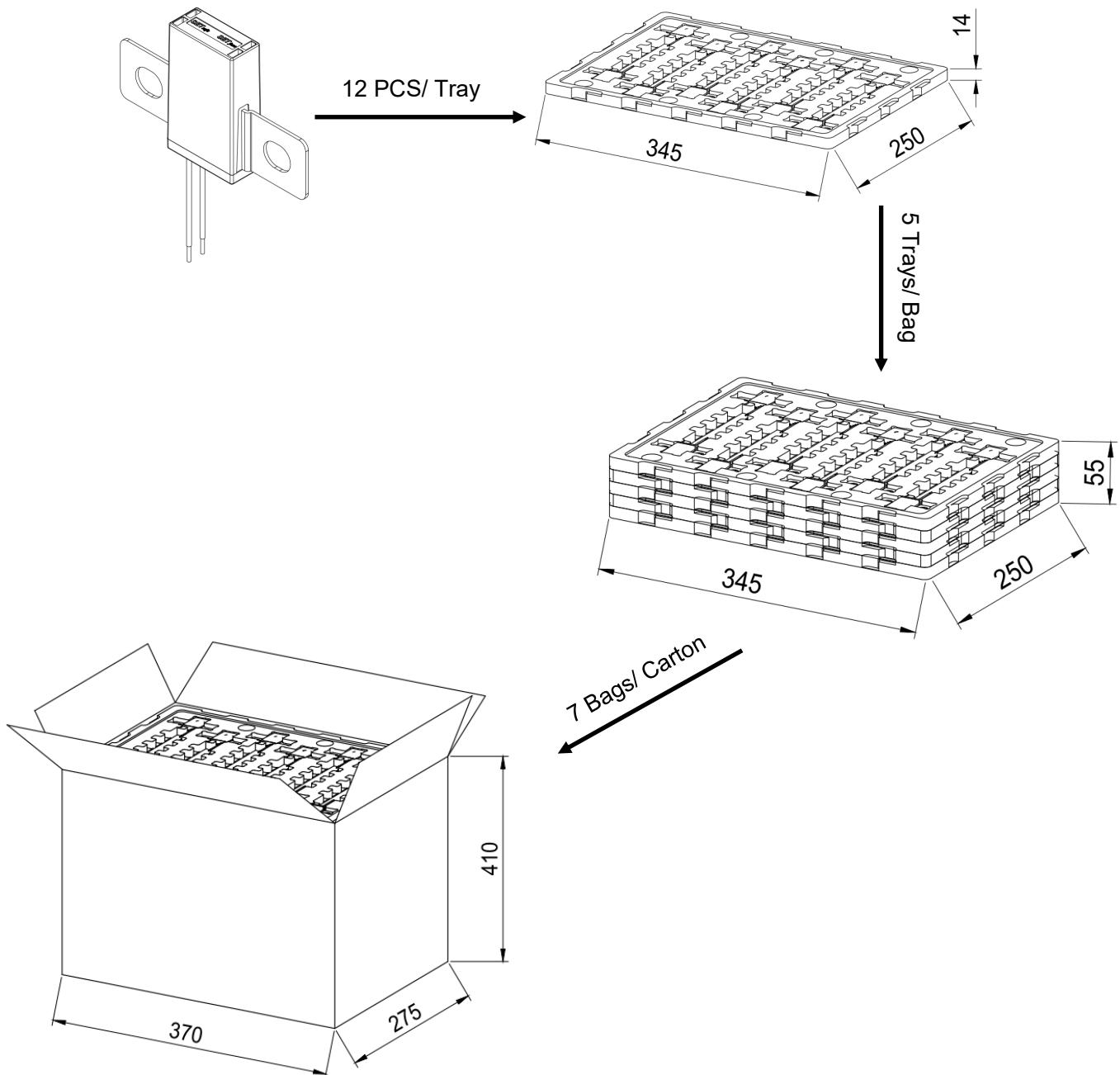



ATTENTION

Usage

1. When atmosphere press is from 80 kPa to 106 kPa, the related altitude shall be from 2,000 meter to - 500 meter.
2. Operating voltage shall be less than rated voltage of iTCO, operating current shall be less than rated current of iTCO.
3. Do not touch the iTCO body or electrode lead directly when power is on, to avoid burn or electric shock.

Electrical Connections

Mechanical Connection MC

1. The product surface must not be damaged.
2. If adding terminals to electrode leads, make sure the electrode without grease or other foreign matters, and use the same cross-section connection terminal, otherwise the electrode may heat abnormally.
3. If locking with screw, to prevent loosening, please add gasket and use proper screw when installing the product. Ensure that the screw tightening torque meets the requirements.

Soldering CC

1. Soldering should be carried out under the soldering conditions listed in table -1.
2. Feed heater and remote signal CC, improper soldering operation (too high soldering temperature, too long soldering time, too short lead wire etc.) may cause CC to open in advance.
3. When soldering conditions are more severe than those listed in table -1, a heat sink fixture should be used between solder point and iTCO body.

Table -1 Hand - Soldering Time (s)

The Max. Allowable Soldering Time for Different Lead Length (s)						Max. Soldering Temp.
Lead Length	Max. Allowable Soldering Time	Lead Length	Max. Allowable Soldering Time	Lead Length	Max. Allowable Soldering Time	
(mm)	(s)	(mm)	(s)	(mm)	(s)	(°C)
≤10	8	10 ~ 20	9	20 ~ 30	9	400

Test Methods

Cold Resistance Test

1. If product TCR is not less than 350 E (-6) / °C and the test ambient Temperature is during 15 °C to 35 °C, the measured resistance value shall be corrected as the relative resistance value under 25 °C according to TCR formula.
2. Resistance measurement (Four - point probe).

Replacement

iTCO is the non-resettable product, for safety sake, please use the same type of iTCO for replacement.

Storage

And iTCO must be kept in a place with no sunshine or no pollution, with temp. (10 to 30) °C and humidity within (30 to 70) %. To avoid influencing the solder-ability of the leads and influencing contact resistance, please use them up within 1 year after receiving the goods.