

TVS Diodes

Transient Voltage Suppression Diodes

3.0SMCJ Series



TVS

TVS

Description

Transient Voltage Suppressor (TVS) is a circuit protection component that either attenuates (reduces) or filters a transient voltage spike (overvoltage), TVS diodes provide critical protection by going into avalanche breakdown within no more than a few nanoseconds after a strike, clamping the transient voltage, and routing its current to the ground.

Applications

- Communication Equipment
- Security & Protection
- Industrial Control Equipment
- Power Supply
- Automotive Electronics
- New Energy
- Lightning Protection

Functional Diagram

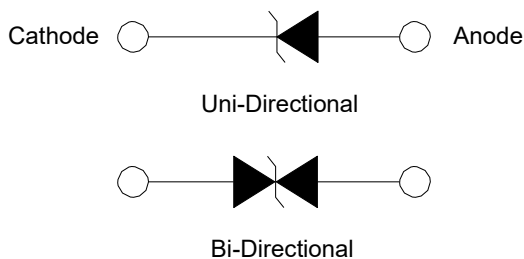

Features

- Low incremental surge resistance
- Excellent clamping capability
- Low profile package with built-in strain relief
- 3000 W peak pulse power capability with a 10/1000 μ S Waveform, repetition rate (duty cycle): 0.01%
- For surface mounted applications to optimize board space
- Typical failure mode is short from over-specified voltage or current
- IEC 61000-4-2 ESD 30 kV (Air), 30 kV (Contact)
- EFT protection of data lines in accordance with IEC 61000 -4-4
- Very fast response time
- Glass passivated chip junction
- High temperature to reflow soldering guaranteed: 260 °C/30sec
- $V_{BR} @ T_J = V_{BR@25\text{ }^\circ\text{C}} \times (1 + \alpha T \times (T_J - 25))$
(αT : Temperature Coefficient, typical value is 0.1%)
- Plastic package is flammability rated V-0 per Underwriters Laboratories
- Meet MSL level1, per J-STD-020
- Matte tin lead-free plated
- Halogen free and RoHS compliant
- Pb-free E3 means 2nd level interconnect is Pb-free and the terminal finish material is tin(Sn) (IPC/JEDEC J-STD-609A.01)

Package Outline Dimensions (DO-214AB)

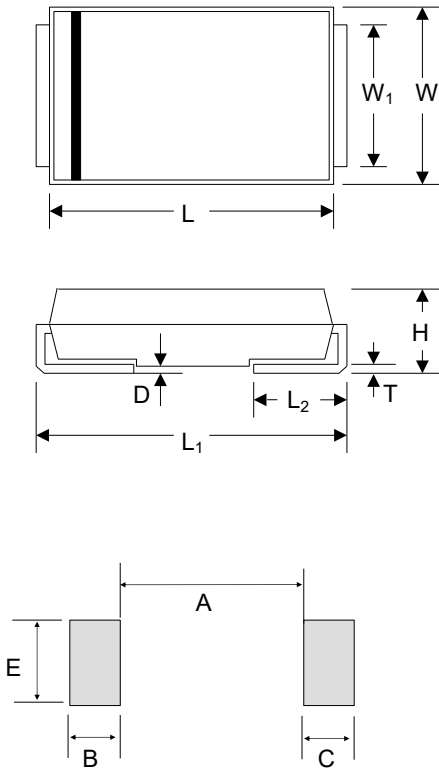

Symbol	Millimeters		Inches	
	Min.	Max.	Min.	Max.
L	6.600	7.110	0.260	0.280
W	5.590	6.220	0.220	0.245
W ₁	2.900	3.200	0.114	0.126
H	2.060	2.620	0.079	0.103
T	0.1520	0.305	0.006	0.012
L ₁	7.750	8.130	0.305	0.320
L ₂	0.760	1.520	0.030	0.060
D	-	0.203	-	0.008
A	-	4.200	-	0.165
B	2.400	-	0.094	-
C	2.400	-	0.094	-
E	3.300	-	0.129	-

Mounting Pad Layout

Maximum Ratings and Characteristics

(Ratings at 25 °C ambient temperature unless otherwise specified.)

Parameter	Symbol	Value	Unit
Peak Power Dissipation(Fig.2)- with a 10/1000 μS waveform(Fig.4)	P _{PPM}	3000	W
Peak Power Dissipation on Infinite Heat Sink at T _L =50 °C	P _D	6.5	W
Peak Forward Surge Current,8.3 ms single half sinewave superimposed on rated load (JEDEC Method) ⁽¹⁾	I _{FSM}	200	A
Maximum Instantaneous Forward Voltage at 100 A for Unidirectional Only	V _F	3.5	V
Operating Temperature Range	T _J	-65 to 150	°C
Storage Temperature Range	T _{STG}	-65 to 175	°C
Typical Thermal Resistance Junction to Lead	R _{θJL}	15	°C / W
Typical Thermal Resistance Junction to Ambient	R _{θJA}	75	°C / W

Note

1.Measured of 8.3 ms single half sine-wave or equivalent square wave, duty cycle=4 pulses per minute maximum.

TVS Diodes

Transient Voltage Suppression Diodes

3.0SMCJ Series

Part Numbering System

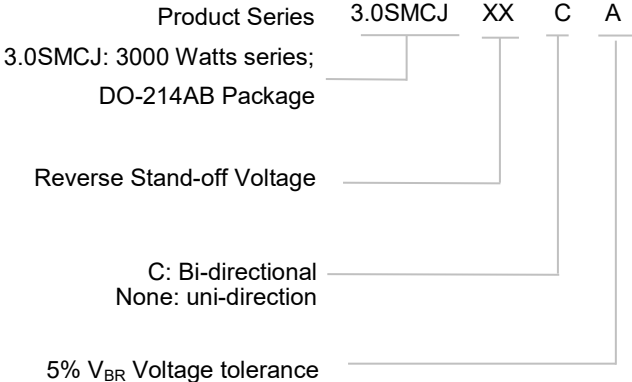

Marking

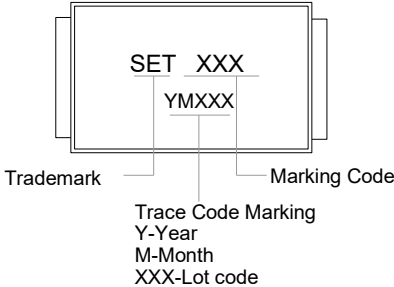
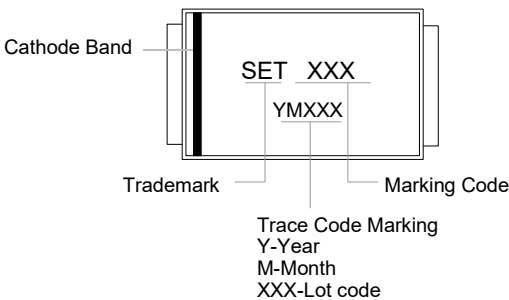

Glossary

Item	Description
V_C	Clamping Voltage Voltage across TVS in a region of low differential resistance that serves to limit the voltage across the device terminals.
V_R	Reverse Stand-off Voltage Maximum voltage that can be applied to the TVS without operation. NOTE : It is also shown as V_{WM} (maximum working voltage (maximum d.c. voltage)) and known as rated stand-off voltage (V_{so}).
I_R	Reverse Leakage Current Current measured at V_R .
V_{BR}	Breakdown Voltage Voltage across TVS at a specified current I_T in the breakdown region.
I_{PPM}	Rated Random Recurring Peak Impulse Current Maximum-rated value of random recurring peak impulse current that may be applied to a device.
$P_{M(AV)}$	Rated Average Power Dissipation Maximum-rated value of power dissipation resulting from all sources, including transients and standby current, averaged over a short period of time.
P_{PPM}	Rated Random Recurring Peak Impulse Power Dissipation Maximum-rated value of the product of rated random recurring peak impulse current (I_{PPM}) multiplies by specified maximum clamping voltage (V_C).
C_J	Capacitance Capacitance across the TVS measured at a specified frequency and voltage.
V_{FS}	Peak Forward Surge Voltage Peak voltage across an TVS for a specified forward surge current (I_{FS}) and time duration. NOTE : Also shown as V_F .
I_{FS}	Forward Surge Current Pulsed current through TVS in the forward conducting region. NOTE : Also shown as I_F .
$\alpha_{V(BR)}$	Temperature Coefficient of Breakdown Voltage The change of breakdown voltage divided by the change of temperature.
I_{PP}	Peak pulse Current Peak pulse current value applied across the TVS to determine the clamping voltage V_C for a specified wave shape.
I_T	Pulsed D.C. Test Current Test current for measurement of the breakdown voltage V_{BR} . This is defined by the manufacturer and usually given in milliamperes with a pulse duration of less than 40 ms. NOTE : Also shown as I_{BR} .

—(GB-T 18802.321 / IEC 61643-321 / JESD210A)

TVS Diodes

Transient Voltage Suppression Diodes

3.0SMCJ Series

Electrical Characteristics (T_A=25 °C unless otherwise noted)Table 1

Part Number		Device Marking Code		Breakdown Voltage V _{BR} @I _T		Test Current I _T	Reverse Stand-off Voltage V _R	Max. Reverse Leakage I _R @V _R	Max. Peak Pulse Current I _{PPM}	Max. Clamping Voltage V _C @I _{PPM}
				Min	Max					
Uni	Bi	Uni	Bi	(V)		(mA)	(V)	(μA)	(A)	(V)
3.0SMCJ5.0	3.0SMCJ5.0C	3CAD	3CWD	6.40	7.82	10	5.0	1000	312.5	9.6
3.0SMCJ5.0A	3.0SMCJ5.0CA	3CAE	3CWE	6.40	7.07	10	5.0	1000	326.1	9.2
3.0SMCJ6.0	3.0SMCJ6.0C	3CAF	3CWF	6.67	8.15	10	6.0	1000	263.2	11.4
3.0SMCJ6.0A	3.0SMCJ6.0CA	3CAG	3CWG	6.67	7.37	10	6.0	1000	291.3	10.3
3.0SMCJ6.5	3.0SMCJ6.5C	3CAH	3CWH	7.22	8.82	10	6.5	500	243.9	12.3
3.0SMCJ6.5A	3.0SMCJ6.5CA	3CAK	3CWK	7.22	7.98	10	6.5	500	267.9	11.2
3.0SMCJ6.8	3.0SMCJ6.8C	3CED	3CFD	7.56	9.22	10	6.8	500	247.9	12.1
3.0SMCJ6.8A	3.0SMCJ6.8CA	3CEE	3CFE	7.56	8.35	10	6.8	500	250.0	12.0
3.0SMCJ7.0	3.0SMCJ7.0C	3CAL	3CWL	7.78	9.51	10	7.0	200	225.6	13.3
3.0SMCJ7.0A	3.0SMCJ7.0CA	3CAM	3CWM	7.78	8.60	10	7.0	200	250.0	12.0
3.0SMCJ7.5	3.0SMCJ7.5C	3CAN	3CWN	8.33	10.2	1.0	7.5	100	209.8	14.3
3.0SMCJ7.5A	3.0SMCJ7.5CA	3CAP	3CWP	8.33	9.21	1.0	7.5	100	232.6	12.9
3.0SMCJ8.0	3.0SMCJ8.0C	3CAQ	3CWQ	8.89	10.9	1.0	8.0	50	200.0	15.0
3.0SMCJ8.0A	3.0SMCJ8.0CA	3CAR	3CWR	8.89	9.83	1.0	8.0	50	220.6	13.6
3.0SMCJ8.5	3.0SMCJ8.5C	3CAS	3CWS	9.44	11.5	1.0	8.5	20	188.7	15.9
3.0SMCJ8.5A	3.0SMCJ8.5CA	3CAT	3CWT	9.44	10.4	1.0	8.5	20	208.3	14.4
3.0SMCJ9.0	3.0SMCJ9.0C	3CAU	3CWU	10.0	12.2	1.0	9.0	10	177.5	16.9
3.0SMCJ9.0A	3.0SMCJ9.0CA	3CAV	3CWV	10.0	11.1	1.0	9.0	10	194.8	15.4
3.0SMCJ10	3.0SMCJ10C	3CAW	3CWW	11.1	13.6	1.0	10	3.0	159.6	18.8
3.0SMCJ10A	3.0SMCJ10CA	3CAX	3CWX	11.1	12.3	1.0	10	3.0	176.5	17.0
3.0SMCJ11	3.0SMCJ11C	3CAY	3CWY	12.2	14.9	1.0	11	3.0	149.3	20.1
3.0SMCJ11A	3.0SMCJ11CA	3CAZ	3CWZ	12.2	13.5	1.0	11	3.0	164.8	18.2
3.0SMCJ12	3.0SMCJ12C	3CBD	3CXD	13.3	16.3	1.0	12	3.0	136.4	22.0
3.0SMCJ12A	3.0SMCJ12CA	3CBE	3CXE	13.3	14.7	1.0	12	3.0	150.8	19.9
3.0SMCJ13	3.0SMCJ13C	3CBF	3CXF	14.4	17.6	1.0	13	3.0	126.1	23.8
3.0SMCJ13A	3.0SMCJ13CA	3CBG	3CXG	14.4	15.9	1.0	13	3.0	139.5	21.5
3.0SMCJ14	3.0SMCJ14C	3CBH	3CXH	15.6	19.1	1.0	14	3.0	116.3	25.8
3.0SMCJ14A	3.0SMCJ14CA	3CBK	3CXK	15.6	17.2	1.0	14	3.0	129.3	23.2
3.0SMCJ15	3.0SMCJ15C	3CBL	3CXL	16.7	20.4	1.0	15	3.0	111.5	26.9
3.0SMCJ15A	3.0SMCJ15CA	3CBM	3CXM	16.7	18.5	1.0	15	3.0	123.0	24.4
3.0SMCJ16	3.0SMCJ16C	3CBN	3CXN	17.8	21.8	1.0	16	3.0	104.2	28.8
3.0SMCJ16A	3.0SMCJ16CA	3CBP	3CXP	17.8	19.7	1.0	16	3.0	115.4	26.0

TVS Diodes

Transient Voltage Suppression Diodes

3.0SMCJ Series

Part Number		Device Marking Code		Breakdown Voltage $V_{BR}@I_T$		Test Current I_T	Reverse Stand-off Voltage V_R	Max. Reverse Leakage $I_R@V_R$	Max. Peak Pulse Current I_{PPM}	Max. Clamping Voltage $V_C@I_{PPM}$
				Min	Max					
Uni	Bi	Uni	Bi	(V)		(mA)	(V)	(μ A)	(A)	(V)
3.0SMCJ17	3.0SMCJ17C	3CBQ	3CXQ	18.9	23.1	1.0	17	3.0	98.4	30.5
3.0SMCJ17A	3.0SMCJ17CA	3CBR	3CXR	18.9	20.9	1.0	17	3.0	108.7	27.6
3.0SMCJ18	3.0SMCJ18C	3CBS	3CXS	20.0	24.4	1.0	18	3.0	93.2	32.2
3.0SMCJ18A	3.0SMCJ18CA	3CBT	3CXT	20.0	22.1	1.0	18	3.0	102.7	29.2
3.0SMCJ20	3.0SMCJ20C	3CBU	3CXU	22.2	27.1	1.0	20	3.0	83.8	35.8
3.0SMCJ20A	3.0SMCJ20CA	3CBV	3CXV	22.2	24.5	1.0	20	3.0	92.6	32.4
3.0SMCJ22	3.0SMCJ22C	3CBW	3CXW	24.4	29.8	1.0	22	3.0	76.1	39.4
3.0SMCJ22A	3.0SMCJ22CA	3CBX	3CXX	24.4	26.9	1.0	22	3.0	84.5	35.5
3.0SMCJ24	3.0SMCJ24C	3CBY	3CXY	26.7	32.6	1.0	24	3.0	69.8	43.0
3.0SMCJ24A	3.0SMCJ24CA	3CBZ	3CXZ	26.7	29.5	1.0	24	3.0	77.1	38.9
3.0SMCJ26	3.0SMCJ26C	3CCD	3CYD	28.9	35.3	1.0	26	3.0	64.4	46.6
3.0SMCJ26A	3.0SMCJ26CA	3CCE	3CYE	28.9	31.9	1.0	26	3.0	71.3	42.1
3.0SMCJ28	3.0SMCJ28C	3CCF	3CYF	31.1	38.0	1.0	28	3.0	60.0	50.0
3.0SMCJ28A	3.0SMCJ28CA	3CCG	3CYG	31.1	34.4	1.0	28	3.0	66.1	45.4
3.0SMCJ30	3.0SMCJ30C	3CCH	3CYH	33.3	40.7	1.0	30	3.0	56.1	53.5
3.0SMCJ30A	3.0SMCJ30CA	3CCK	3CYK	33.3	36.8	1.0	30	3.0	62.0	48.4
3.0SMCJ33	3.0SMCJ33C	3CCL	3CYL	36.7	44.9	1.0	33	3.0	50.8	59.0
3.0SMCJ33A	3.0SMCJ33CA	3CCM	3CYM	36.7	40.6	1.0	33	3.0	56.3	53.3
3.0SMCJ36	3.0SMCJ36C	3CCN	3CYN	40.0	48.9	1.0	36	3.0	46.7	64.3
3.0SMCJ36A	3.0SMCJ36CA	3CCP	3CYP	40.0	44.2	1.0	36	3.0	51.6	58.1
3.0SMCJ40	3.0SMCJ40C	3CCQ	3CYQ	44.4	54.3	1.0	40	3.0	42.0	71.4
3.0SMCJ40A	3.0SMCJ40CA	3CCR	3CYR	44.4	49.1	1.0	40	3.0	46.5	64.5
3.0SMCJ43	3.0SMCJ43C	3CCS	3CYS	47.8	58.4	1.0	43	3.0	39.1	76.7
3.0SMCJ43A	3.0SMCJ43CA	3CCT	3CYT	47.8	52.8	1.0	43	3.0	43.2	69.4
3.0SMCJ45	3.0SMCJ45C	3CCU	3CYU	50.0	61.1	1.0	45	3.0	37.4	80.3
3.0SMCJ45A	3.0SMCJ45CA	3CCV	3CYV	50.0	55.3	1.0	45	3.0	41.3	72.7
3.0SMCJ48	3.0SMCJ48C	3CCW	3CYW	53.3	65.1	1.0	48	3.0	35.1	85.5
3.0SMCJ48A	3.0SMCJ48CA	3CCX	3CYX	53.3	58.9	1.0	48	3.0	38.8	77.4
3.0SMCJ51	3.0SMCJ51C	3CCY	3CYY	56.7	69.3	1.0	51	3.0	32.9	91.1
3.0SMCJ51A	3.0SMCJ51CA	3CCZ	3CZY	56.7	62.7	1.0	51	3.0	36.4	82.4
3.0SMCJ54	3.0SMCJ54C	3CRD	3CZD	60.0	73.3	1.0	54	3.0	31.2	96.3
3.0SMCJ54A	3.0SMCJ54CA	3CRE	3CZE	60.0	66.3	1.0	54	3.0	34.4	87.1

TVS Diodes

Transient Voltage Suppression Diodes

3.0SMCJ Series

Part Number		Device Marking Code		Breakdown Voltage $V_{BR}@I_T$		Test Current I_T	Reverse Stand-off Voltage V_R	Max. Reverse Leakage $I_R@V_R$	Max. Peak Pulse Current I_{PPM}	Max. Clamping Voltage $V_C@I_{PPM}$
				Min	Max					
Uni	Bi	Uni	Bi	(V)		(mA)	(V)	(μ A)	(A)	(V)
3.0SMCJ58	3.0SMCJ58C	3CRF	3CZF	64.4	78.7	1.0	58	3.0	29.1	103
3.0SMCJ58A	3.0SMCJ58CA	3CRG	3CZG	64.4	71.2	1.0	58	3.0	32.1	93.6
3.0SMCJ60	3.0SMCJ60C	3CRH	3CZH	66.7	81.5	1.0	60	3.0	28.0	107
3.0SMCJ60A	3.0SMCJ60CA	3CRK	3CZK	66.7	73.7	1.0	60	3.0	31.0	96.8
3.0SMCJ64	3.0SMCJ64C	3CRN	3CZN	71.1	86.9	1.0	64	3.0	26.3	114
3.0SMCJ64A	3.0SMCJ64CA	3CRP	3CZP	71.1	78.6	1.0	64	3.0	29.1	103
3.0SMCJ68	3.0SMCJ68C	3CRB	3CZB	75.5	92.3	1.0	68	3.0	24.8	121
3.0SMCJ68A	3.0SMCJ68CA	3CRC	3CZC	75.5	83.5	1.0	68	3.0	27.5	109
3.0SMCJ70	3.0SMCJ70C	3CEH	3CFH	77.8	95.1	1.0	70	3.0	24.0	125
3.0SMCJ70A	3.0SMCJ70CA	3CEK	3CFK	77.8	86.0	1.0	70	3.0	26.5	113
3.0SMCJ75	3.0SMCJ75C	3CRQ	3CZQ	83.3	102	1.0	75	3.0	22.4	134
3.0SMCJ75A	3.0SMCJ75CA	3CRR	3CZR	83.3	92.1	1.0	75	3.0	24.8	121
3.0SMCJ78	3.0SMCJ78C	3CRS	3CZS	86.7	106	1.0	78	3.0	21.6	139
3.0SMCJ78A	3.0SMCJ78CA	3CRT	3CZT	86.7	95.8	1.0	78	3.0	23.8	126
3.0SMCJ85	3.0SMCJ85C	3CRU	3CZU	94.4	115	1.0	85	3.0	19.9	151
3.0SMCJ85A	3.0SMCJ85CA	3CRV	3CZV	94.4	104	1.0	85	3.0	21.9	137
3.0SMCJ90	3.0SMCJ90C	3CRW	3CZW	100	122	1.0	90	3.0	18.8	160
3.0SMCJ90A	3.0SMCJ90CA	3CRX	3CZX	100	111	1.0	90	3.0	20.5	146
3.0SMCJ100	3.0SMCJ100C	3CRY	3CZY	111	136	1.0	100	3.0	16.8	179
3.0SMCJ100A	3.0SMCJ100CA	3CRZ	3CZZ	111	123	1.0	100	3.0	18.5	162
3.0SMCJ110	3.0SMCJ110C	3CSD	3CVD	122	149	1.0	110	3.0	15.3	196
3.0SMCJ110A	3.0SMCJ110CA	3CSE	3CVE	122	135	1.0	110	3.0	16.9	177
3.0SMCJ120	3.0SMCJ120C	3CSF	3CVF	133	163	1.0	120	3.0	14.0	214
3.0SMCJ120A	3.0SMCJ120CA	3CSG	3CVG	133	147	1.0	120	3.0	15.5	193
3.0SMCJ130	3.0SMCJ130C	3CSH	3CVH	144	176	1.0	130	3.0	13.0	231
3.0SMCJ130A	3.0SMCJ130CA	3CSK	3CVK	144	159	1.0	130	3.0	14.4	209
3.0SMCJ150	3.0SMCJ150C	3CSL	3CVL	167	204	1.0	150	3.0	11.2	268
3.0SMCJ150A	3.0SMCJ150CA	3CSM	3CVM	167	185	1.0	150	3.0	12.3	243
3.0SMCJ160	3.0SMCJ160C	3CSN	3CVN	178	218	1.0	160	3.0	10.5	287
3.0SMCJ160A	3.0SMCJ160CA	3CSP	3CVP	178	197	1.0	160	3.0	11.6	259
3.0SMCJ170	3.0SMCJ170C	3CSQ	3CVQ	189	231	1.0	170	3.0	9.9	304
3.0SMCJ170A	3.0SMCJ170CA	3CSR	3CVR	189	209	1.0	170	3.0	10.9	275

TVS Diodes

Transient Voltage Suppression Diodes

3.0SMCJ Series

Part Number		Device Marking Code		Breakdown Voltage $V_{BR}@I_T$		Test Current I_T	Reverse Stand-off Voltage V_R	Max. Reverse Leakage $I_R@V_R$	Max. Peak Pulse Current I_{PPM}	Max. Clamping Voltage $V_C@I_{PPM}$
				Min	Max					
Uni	Bi	Uni	Bi	(V)		(mA)	(V)	(μ A)	(A)	(V)
3.0SMCJ188	3.0SMCJ188C	3CST	3CVT	209	255	1.0	188	3.0	8.7	344
3.0SMCJ188A	3.0SMCJ188CA	3CSS	3CVS	209	231	1.0	188	3.0	9.1	328
3.0SMCJ200	3.0SMCJ200C	3CSU	3CVU	222	272	1.0	200	3.0	8.4	356
3.0SMCJ200A	3.0SMCJ200CA	3CSV	3CVV	222	246	1.0	200	3.0	9.3	323
3.0SMCJ220	3.0SMCJ220C	3CSW	3CVW	245	299	1.0	220	3.0	7.7	392
3.0SMCJ220A	3.0SMCJ220CA	3CSX	3CVX	245	270	1.0	220	3.0	8.5	355
3.0SMCJ240	3.0SMCJ240C	3CSY	3CVY	267	326	1.0	240	3.0	7.0	428
3.0SMCJ240A	3.0SMCJ240CA	3CSZ	3CVZ	267	295	1.0	240	3.0	7.7	388
3.0SMCJ250	3.0SMCJ250C	3CTS	3CUS	278	340	1.0	250	3.0	6.7	446
3.0SMCJ250A	3.0SMCJ250CA	3CTT	3CUT	278	307	1.0	250	3.0	7.4	404
3.0SMCJ300	3.0SMCJ300C	3CTF	3CUF	333	408	1.0	300	3.0	5.6	535
3.0SMCJ300A	3.0SMCJ300CA	3CTG	3CUG	333	368	1.0	300	3.0	6.2	485
3.0SMCJ350	3.0SMCJ350C	3CTQ	3CUQ	389	476	1.0	350	3.0	4.8	624
3.0SMCJ350A	3.0SMCJ350CA	3CTR	3CUR	389	429	1.0	350	3.0	5.3	566
3.0SMCJ360	3.0SMCJ360C	3CTH	3CUH	400	489	1.0	360	3.0	4.6	652
3.0SMCJ360A	3.0SMCJ360CA	3CTK	3CUK	400	442	1.0	360	3.0	5.2	582
3.0SMCJ400	3.0SMCJ400C	3CTL	3CUL	445	544	1.0	400	3.0	4.2	713
3.0SMCJ400A	3.0SMCJ400CA	3CTM	3CUM	445	491	1.0	400	3.0	4.6	646
3.0SMCJ440	3.0SMCJ440C	3CTN	3CUN	489	598	1.0	440	3.0	3.8	784
3.0SMCJ440A	3.0SMCJ440CA	3CTP	3CUP	489	540	1.0	440	3.0	4.2	711

Notes:

1. For bidirectional type having V_R of 10 volts and less, the I_R should be doubled.
2. For parts without A in the PN, the V_{BR} tolerance is $\pm 10\%$ and V_C is 5% higher than parts with A. The parts without A are currently available, but not recommended for new designs. The parts with A are preferred.

I-V Curve Characteristics

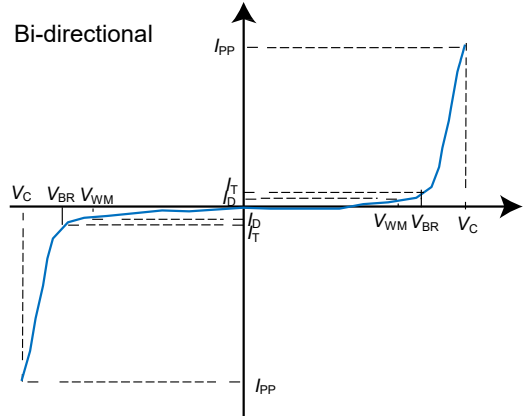
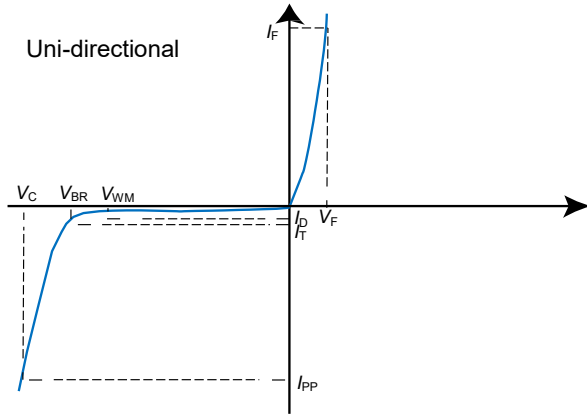

Performance Curve for Reference ($T_A=25^\circ\text{C}$ unless otherwise noted)

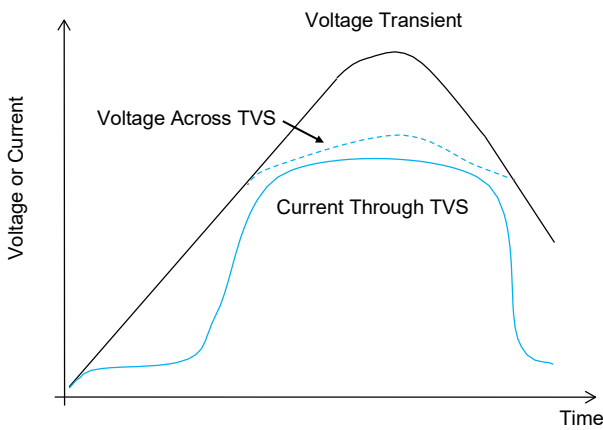

FIGURE 1 TVS Transients Clamping Waveform

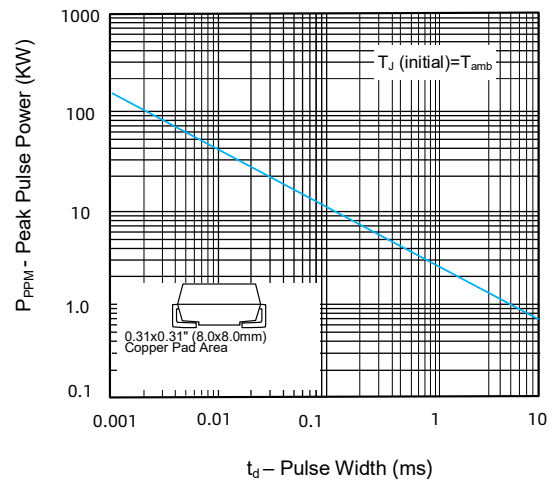

FIGURE 2 Peak Pulse Power Rating Curve

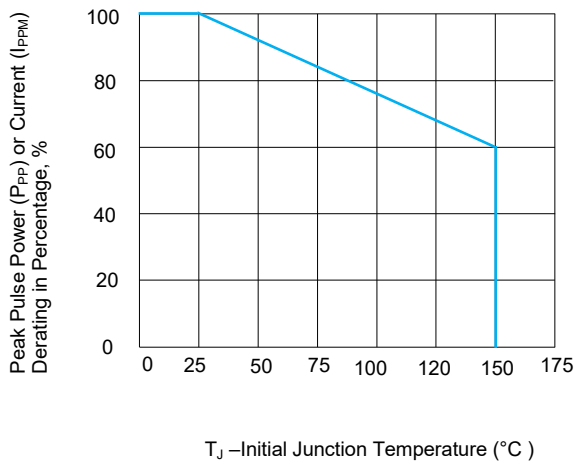

FIGURE 3 Peak Pulse Power Derating Curve

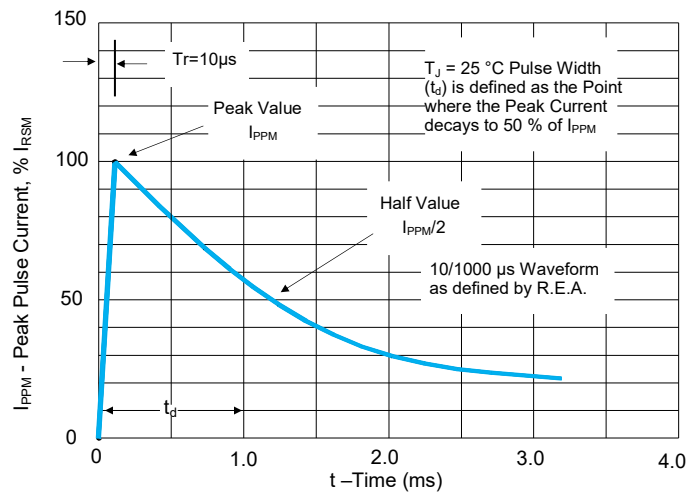

FIGURE 4 Pulse Waveform

TVS Diodes

Transient Voltage Suppression Diodes

3.0SMCJ Series

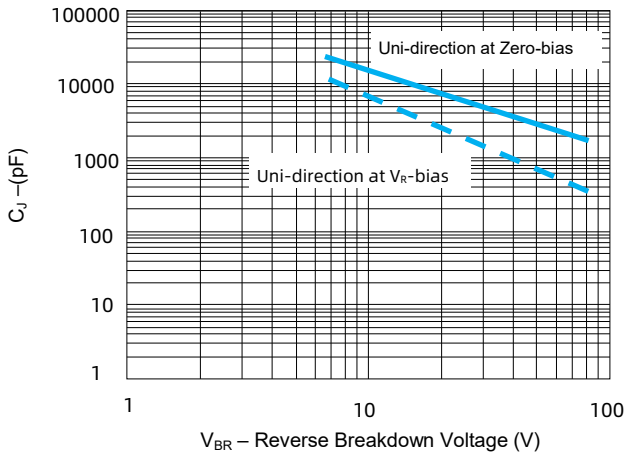

FIGURE 5 Typical Junction Capacitance

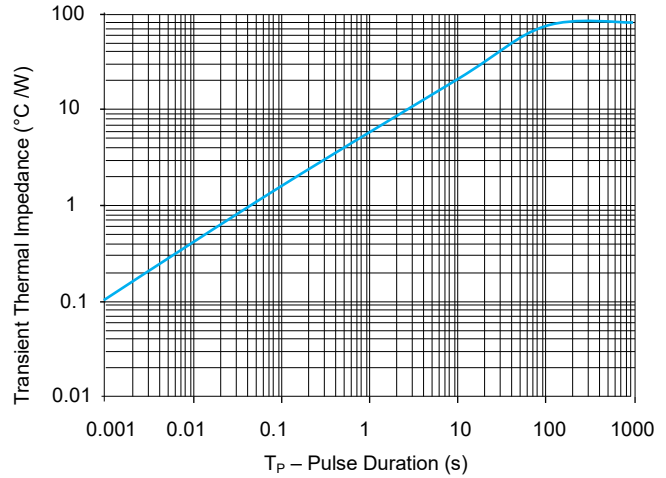

FIGURE 6 Typical Transient Thermal Impedance

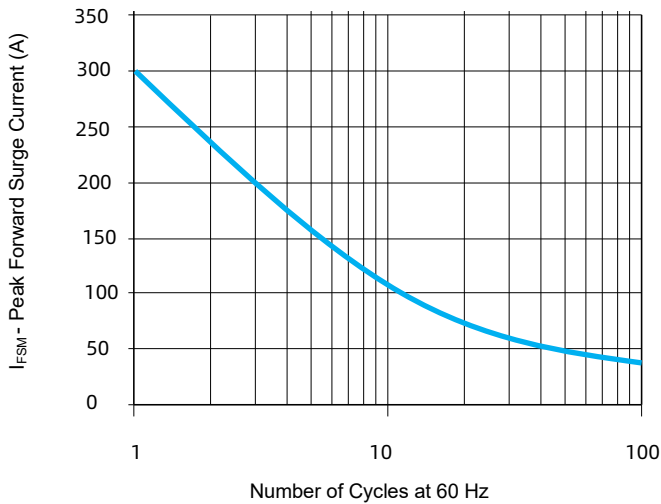

FIGURE 7 Maximum Non-Repetitive Forward Surge Current Uni-Directional only

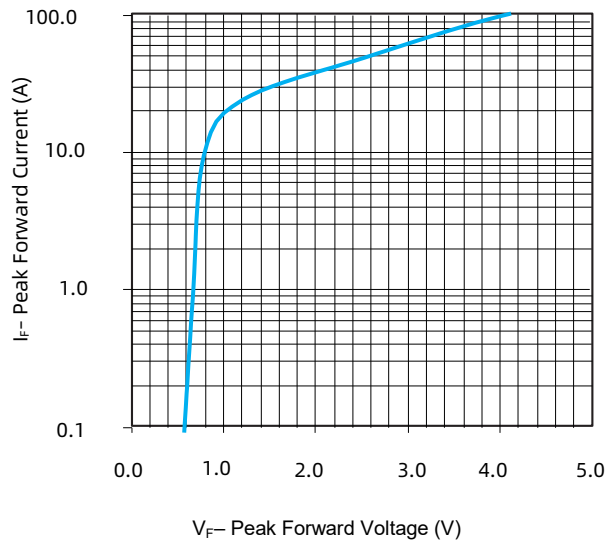

FIGURE 8 Peak Forward Drop vs Peak Forward Current (Typical Values)

Environmental Specifications

High Temp. Storage	JESD22-A103
HTRB	JESD22-A108
Temperature Cycling	JESD22-A104
MSL	JESDEC-J-STD-020, Level 1
H3TRB	JESD22-A101
RSH	JESD22-A111

Physical Specifications

Weight	0.007 ounce, 0.21 grams
Case	JESD22DO214AB. Molded plastic body over glass passivated junction
Polarity	Color band denotes positive end (cathode) except Bidirectional
Terminal	Matte Tin-plated leads, Solderability per JESD22-B102

Soldering Parameters

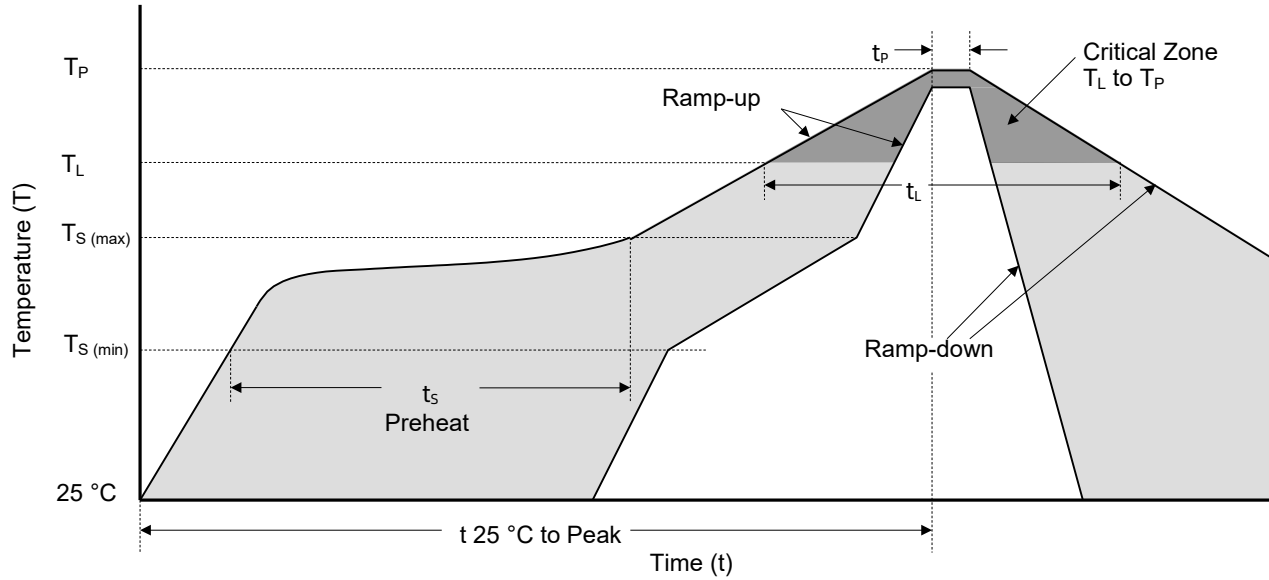

Reflowing Condition

Reflow Soldering Parameters		Lead-Free Assembly
Pre-heat	Temperature Min (TS (min))	150 °C
	Temperature Max (TS (max))	200 °C
	Time (min to max) (ts)	60 ~ 120 seconds
Average Ramp Up Rate (Liquidus Temp (TL) to Peak)		3 °C / second max.
TS (max) to TL Ramp-up Rate		3 °C / second max.
Reflow	Temperature (TL) (Liquidus)	217 °C
	Time (min to max) (tL)	60 ~ 150 seconds
Peak Temperature (TP)		260 ^{+0/-5} °C
Time of within 5 °C of Actual Peak Temperature (tp)		20 ~ 40 seconds
Ramp-down Rate		6 °C / second max.
Time from 25 °C to Peak Temperature		8 Minutes max.
Do Not Exceed		260 °C

TVS Diodes

Transient Voltage Suppression Diodes

3.0SMCJ Series

Packaging Information

Tape	Symbol	Dimension (mm)
	W	16.00 + 0.3 / - 0.1
	P ₀	4.00 ± 0.10
	P ₁	8.00 ± 0.10
	P ₂	2.00 ± 0.10
	D ₀	1.55 ± 0.05
	D ₁	1.55 ± 0.05
	E	1.75 ± 0.10
	F	7.50 ± 0.10
	A ₀	6.15 ± 0.10
	B ₀	8.30 ± 0.10
	K ₀	2.48 ± 0.10
	T	0.30 ± 0.05

Reel Size	13" Reel	
	A	330 mm
	C	13.2 mm
	W ₁	16.4 mm

Part Number	Package	QTY (Reel)	Packaging Option	Packaging Specification
3.0SMCJxxx	DO-214AB	3000 PCS	Tape & Reel – 16 mm tape/13" reel	EIA STD RS-481



ATTENTION

Usage

1. TVS must be operated in the specified ambient temp.
2. Do not clean the TVS with strong polar solvent such as ketone, esters, benzene and halogenated hydrocarbon, to avoid damaging the encapsulating layer.
3. Please do not apply severe vibration, shock or pressure to TVS, to avoid element cracking.

Replacement

1. If TVS is visually damaged, please replace it.
2. TVS is a non-repairable product. For safety sake, please use equivalent TVS for replacement.

Storage

1. Storage Temp. Range: (-55 to 150) °C.
2. Do not store the TVS at the high temp., high humidity or corrosive gas environment, to avoid influencing the solderability of the lead wires. The product shall be used up within 1 year after receiving the goods.

Environmental Conditions

1. TVS should not be exposed to the open air, nor direct sunshine.
2. TVS should avoid rain, water vapor or other condition of high temp. and high humidity.
3. TVS should avoid sand dust, salt mist, or other harmful gases.

Max. Typical Capacitance of TVS

The typical capacitance of TVS is listed in the specifications. Designers may refer to it when designing TVS in High frequency circuit.

Installation Mechanical Stress

1. Do not knock TVS when installing, to avoid mechanical damage.
2. Please do not apply severe vibration, shock or pressure to TVS, to avoid surface resin or element cracking.