



## Description

TFV series consists of Metal Oxide Varistor&Thermal Protection Element. The built-in thermal protection element can quickly respond to the Over-temperature of the varistor to provide instant protection.The integrated struduce of TFV has lower inductance and better ability to suppress surge and overvoltage .





## Features

- Patented Product
- Thermal Protection Varistor
- Thermal Protection Elements Are Built In To Save Space
- Three-lead Version Available For Indication Purpose
- Low Leakage
- Operatin Temp. Range:(-40 to 105)°C
- RoHS & REACH Compliant

## Applications

- Power Supplies
- Home Electrical Appliances
- Industrial Devices
- Surge Protectors
- Telecom Devices
- AC Panel Protection Modules
- AC Power Meters
- GFCI (Ground Fault Current Interrupter)
- UPS (Uninterruptable Power Supply)
- Inverters

## Agency Approvals

Agency	Standards	File No.
	UL 1449 4 <sup>th</sup> Edition	E322662
	CSA C22.2 NO.269.5-17	E322662
	EN IEC 61051-1:2018 IEC 61051-2:1991+A1 IEC 61051-2-2:1991 Annex G.8.1, G.8.2 of IEC 62368-1:2018	J 50554143
	GB/T 10193-1997 GB/T 10194-1997 GB 4943.1-2011 GB 8898-2011	On-going

## Product Structure

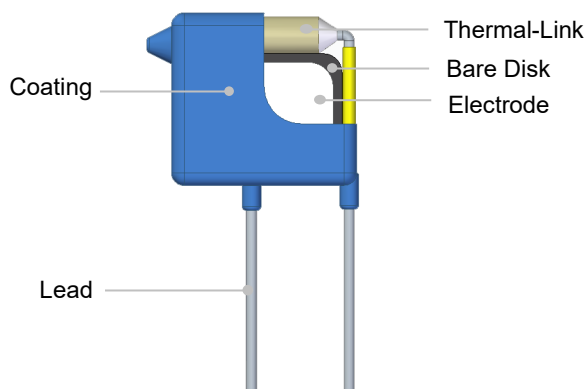

## Schematics

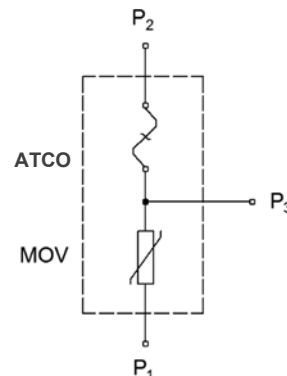
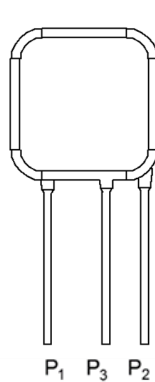
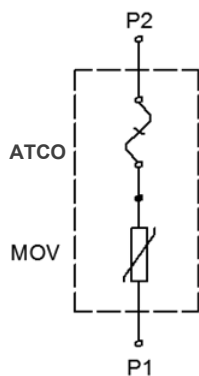
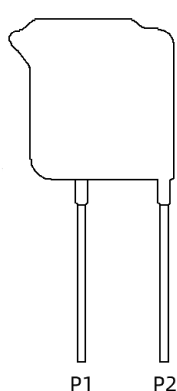

### Marking

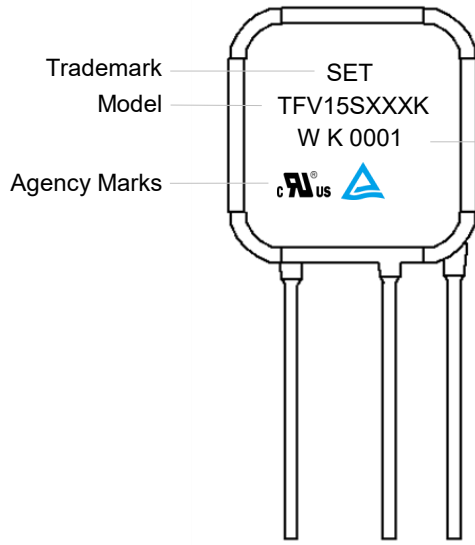

Internal code	
Year Code	2000—A ..... 2022—W
Surge Level	K: Standard Type
Serial No.	(E.G.: 0001)

### Temp. Derating Curve

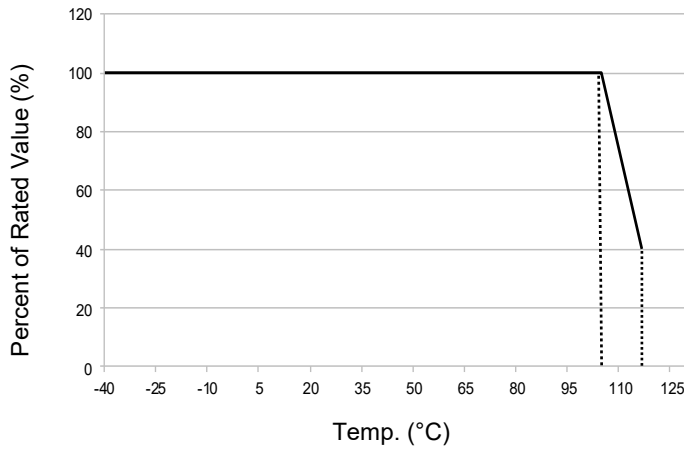

Note:  
When ambient Temp. exceeds 105 °C, the peak surge current and energy rating should be reduced as shown in left curve.

For Normal Temp. Series

### General Technical Data

Item	Value	Unit
Operating Temperature	-40 to +105	°C
Storage Temperature	-40 to +125	°C
Voltage Proof	≥2500	V <sub>ac</sub>
Insulation Resistance	≥100	MΩ

**Part Numbering System**

TFV 15 S 471 - K 3 P K A BUL - 001

TFV

TFV

**Other Options**

**\*Packaging & Lead Length**

BUL: Bulk + Standard Lead Length  
(Normal L28)

**Lead Type**

A: Straight Lead

**Surge Level**

K: Standard Type

**Operating Temp.**

P: Epoxy Coating 105 °C

**Lead**

2: 2 PIN  
3: 3 PIN

**Voltage Tolerance**

K: ±10%  
J: ±5%  
S: Special Tolerance

**Nominal Varistor Voltage**

220:  $22 \times 10^0 = 22 \text{ V}$   
471:  $47 \times 10^1 = 470 \text{ V}$   
122:  $12 \times 10^2 = 1200 \text{ V}$

**Disk Shape**

S: Square

**Bare Disk Dimension**

15: 15×15 mm

**Product Category**

Metal Oxide Varistor

\*For more details refer to Packaging Information.

## Glossary

Item	Description
$V_N$	<b>Nominal Varistor Voltage</b> Voltage, at specified D.C. current used as a reference point in the component characteristics.
$I_L$	<b>Leakage Current</b> Current passing through the varistor at the max. d.c. voltage, and at a temp. of 25 °C, or any other specified temp.
UCT	<b>Upper Category Temp.</b> Max. ambient temp. for which a varistor has been designed to operate continuously.
LCT	<b>Lower Category Temp.</b> Minimum ambient temp. at which a varistor has been designed to operate continuously.
<b>Max. Peak Current</b>	<b>Max. Peak Current</b> Max. current per pulse, which may be passed by a varistor at an ambient temp. of 25 °C, for a given number of pulses.
$V_C$	<b>Clamping Voltage</b> Peak voltage developed across the varistor terminations under standard atmospheric conditions, when passing an 8/20 $\mu$ s class current pulse.
<b>Voltage Proof</b>	<b>Voltage Proof</b> Max. peak voltage, which may be applied under continuous operating conditions between the varistor terminations and any conducting mounting surface (Applicable only to insulated varistors).
$C_V$	<b>Capacitance</b> Capacitance across the MOV measured at a specified frequency and voltage.
$V_{ac}$	<b>Max. Continuous a.c. Voltage</b> Max. a.c. r.m.s. voltage of a substantially sinusoidal waveform (less than 5% total harmonic distortion) which can be applied to the component under continuous operating conditions at 25 °C.
$V_{dc}$	<b>Max. Continuous d.c. Voltage</b> Max. d.c. voltage (with less than 5% ripple) which can be applied to the component under continuous operating conditions at an ambient temp. of 25 °C.
$I_n$	<b>Nominal Discharge Current</b> Crest value of the current through the SPD having a current waveshape of 8/20 $\mu$ s.
$I_{max}$	<b>Max. Discharge Current</b> Crest value of a current through the SPD having an 8/20 $\mu$ s waveshape and magnitude according to the manufacturers specification. $I_{max}$ is equal to or greater than $I_n$ .
<b>Limited Current</b>	<b>Limited Current</b> UL 1449
$T_f$	<b>Rated function Temp.</b> The Temp. of the TCO which causes it to change its state of conductivity with a detection current up to 10 mA as the only load.
<b>Fuse Temp.</b>	<b>Fuse Temp.</b> IEC 60691
$T_h$	<b>Holding Temp.</b> The Max. temp. of product body surface at which a TCO will not change its state of conductivity when conducting rated current for 168 h.
$U_r$	<b>Rated Voltage</b> The voltage used to classify a TCO, which is the maximum voltage that TCO allows to carry and is able to cut off the circuit safely.

**Dimensions (mm)**

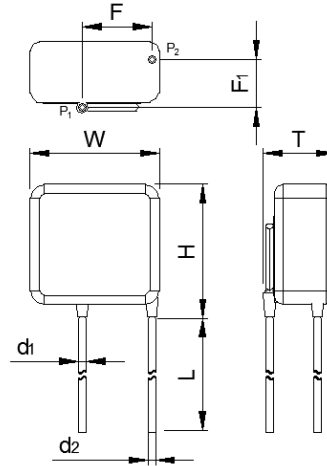

Model	L (Min.)	W (Max.)	H (Max.)	T (Max.)	d <sub>1</sub>	d <sub>2</sub>	F	F <sub>1</sub>
TFV15S820K	15	21	26	4.8	1.00±0.05	1.00±0.05	10.0±1.0	0.4 - 2.4
TFV15S101K	15	21	26	5.0	1.00±0.05	1.00±0.05	10.0±1.0	0.5 - 2.5
TFV15S121K	15	21	26	5.2	1.00±0.05	1.00±0.05	10.0±1.0	0.6 - 2.6
TFV15S151K	15	21	26	5.5	1.00±0.05	1.00±0.05	10.0±1.0	0.8 - 2.8
TFV15S181K	15	21	26	4.9	1.00±0.05	1.00±0.05	10.0±1.0	0.5 - 2.5
TFV15S201K	15	21	26	5.0	1.00±0.05	1.00±0.05	10.0±1.0	0.6 - 2.6
TFV15S221K	15	21	26	5.1	1.00±0.05	1.00±0.05	10.0±1.0	0.6 - 2.6
TFV15S241K	15	21	26	5.2	1.00±0.05	1.00±0.05	10.0±1.0	0.7 - 2.7
TFV15S271K	15	21	26	5.4	1.00±0.05	1.00±0.05	10.0±1.0	0.8 - 2.8
TFV15S301K	15	21	26	5.6	1.00±0.05	1.00±0.05	10.0±1.0	0.9 - 2.9
TFV15S331K	15	21	26	5.8	1.00±0.05	1.00±0.05	10.0±1.0	0.9 - 2.9
TFV15S361K	15	21	26	6.0	1.00±0.05	1.00±0.05	10.0±1.0	1.0 - 3.0
TFV15S391K	15	21	26	6.1	1.00±0.05	1.00±0.05	10.0±1.0	1.1 - 3.1
TFV15S431K	15	21	26	6.4	1.00±0.05	1.00±0.05	10.0±1.0	1.2 - 3.2
TFV15S471K	15	21	26	6.6	1.00±0.05	1.00±0.05	10.0±1.0	1.3 - 3.3
TFV15S511K	15	21	26	6.8	1.00±0.05	1.00±0.05	10.0±1.0	1.5 - 3.5
TFV15S561K	15	21	26	7.1	1.00±0.05	1.00±0.05	10.0±1.0	1.6 - 3.6
TFV15S621K	15	21	26	7.5	1.00±0.05	1.00±0.05	10.0±1.0	1.8 - 3.8
TFV15S681K	15	21	26	7.8	1.00±0.05	1.00±0.05	10.0±1.0	1.9 - 3.9
TFV15S751K	15	21	26	8.3	1.00±0.05	1.00±0.05	10.0±1.0	2.1 - 4.1
TFV15S821K	15	21	26	8.7	1.00±0.05	1.00±0.05	10.0±1.0	2.3 - 4.3

Note:  
The above data is for reference only.

# TFV

Thermal Fuse Varistor

TFV15S Series

## Dimensions (mm)

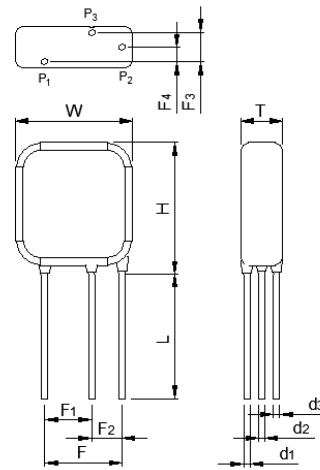
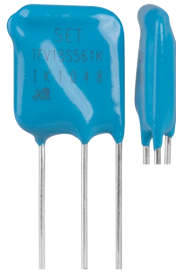

Model	L (Min.)	W (Max.)	H (Max.)	T (Max.)	d <sub>1</sub>	d <sub>2</sub>	d <sub>3</sub>	F	F <sub>1</sub>	F <sub>2</sub>	F <sub>3</sub>	F <sub>4</sub>
TFV15S820K	15	21	26	4.8	1.00±0.05	1.00±0.05	1.00±0.05	12.5±1.0	7.5±1.0	5.0±1.0	1.2 - 2.6	0.4 - 2.4
TFV15S101K	15	21	26	5.0	1.00±0.05	1.00±0.05	1.00±0.05	12.5±1.0	7.5±1.0	5.0±1.0	1.3 - 2.8	0.5 - 2.5
TFV15S121K	15	21	26	5.2	1.00±0.05	1.00±0.05	1.00±0.05	12.5±1.0	7.5±1.0	5.0±1.0	1.4 - 3.0	0.6 - 2.6
TFV15S151K	15	21	26	5.5	1.00±0.05	1.00±0.05	1.00±0.05	12.5±1.0	7.5±1.0	5.0±1.0	1.5 - 3.3	0.8 - 2.8
TFV15S181K	15	21	26	4.9	1.00±0.05	1.00±0.05	1.00±0.05	12.5±1.0	7.5±1.0	5.0±1.0	1.3 - 2.8	0.5 - 2.5
TFV15S201K	15	21	26	5.0	1.00±0.05	1.00±0.05	1.00±0.05	12.5±1.0	7.5±1.0	5.0±1.0	1.4 - 2.9	0.6 - 2.6
TFV15S221K	15	21	26	5.1	1.00±0.05	1.00±0.05	1.00±0.05	12.5±1.0	7.5±1.0	5.0±1.0	1.5 - 3.0	0.6 - 2.6
TFV15S241K	15	21	26	5.2	1.00±0.05	1.00±0.05	1.00±0.05	12.5±1.0	7.5±1.0	5.0±1.0	1.6 - 3.1	0.7 - 2.7
TFV15S271K	15	21	26	5.4	1.00±0.05	1.00±0.05	1.00±0.05	12.5±1.0	7.5±1.0	5.0±1.0	1.7 - 3.3	0.8 - 2.8
TFV15S301K	15	21	26	5.6	1.00±0.05	1.00±0.05	1.00±0.05	12.5±1.0	7.5±1.0	5.0±1.0	1.8 - 3.5	0.9 - 2.9
TFV15S331K	15	21	26	5.8	1.00±0.05	1.00±0.05	1.00±0.05	12.5±1.0	7.5±1.0	5.0±1.0	1.9 - 3.6	0.9 - 2.9
TFV15S361K	15	21	26	6.0	1.00±0.05	1.00±0.05	1.00±0.05	12.5±1.0	7.5±1.0	5.0±1.0	2.0 - 3.8	1.0 - 3.0
TFV15S391K	15	21	26	6.1	1.00±0.05	1.00±0.05	1.00±0.05	12.5±1.0	7.5±1.0	5.0±1.0	2.0 - 4.0	1.1 - 3.1
TFV15S431K	15	21	26	6.4	1.00±0.05	1.00±0.05	1.00±0.05	12.5±1.0	7.5±1.0	5.0±1.0	2.2 - 4.2	1.2 - 3.2
TFV15S471K	15	21	26	6.6	1.00±0.05	1.00±0.05	1.00±0.05	12.5±1.0	7.5±1.0	5.0±1.0	2.4 - 4.4	1.3 - 3.3
TFV15S511K	15	21	26	6.8	1.00±0.05	1.00±0.05	1.00±0.05	12.5±1.0	7.5±1.0	5.0±1.0	2.6 - 4.6	1.5 - 3.5
TFV15S561K	15	21	26	7.1	1.00±0.05	1.00±0.05	1.00±0.05	12.5±1.0	7.5±1.0	5.0±1.0	2.9 - 4.9	1.6 - 3.6
TFV15S621K	15	21	26	7.5	1.00±0.05	1.00±0.05	1.00±0.05	12.5±1.0	7.5±1.0	5.0±1.0	3.2 - 5.2	1.8 - 3.8
TFV15S681K	15	21	26	7.8	1.00±0.05	1.00±0.05	1.00±0.05	12.5±1.0	7.5±1.0	5.0±1.0	3.6 - 5.6	1.9 - 3.9
TFV15S751K	15	21	26	8.3	1.00±0.05	1.00±0.05	1.00±0.05	12.5±1.0	7.5±1.0	5.0±1.0	4.0 - 6.0	2.1 - 4.1
TFV15S821K	15	21	26	8.7	1.00±0.05	1.00±0.05	1.00±0.05	12.5±1.0	7.5±1.0	5.0±1.0	4.4 - 6.4	2.3 - 4.3



Note:

The above data is for reference only.

TFV

TFV

**Specification**

Model	Max. Continuous Operating Voltage		Varistor Voltage @1 mA DC		Clamping Voltage (Max.)		Max. Discharge Current (8/20 μs)		Max. Energy (10/1000 μs)	Typical Capacitance (For reference only) @1 kHz	Agency Approvals			
	Vac	Vdc	Min.	Max.	V <sub>C</sub>	I <sub>P</sub>	I <sub>n</sub>	I <sub>max</sub>			(J)	(pF)		
	(V)	(V)	(V)	(V)	(V)	(A)	(kA)	(kA)	UL	cUL			TUV	CQC
TFV15S820K	50	65	74	90	135	75	5	10	43	4000	●	●	●	○
TFV15S101K	60	85	90	110	165	75	5	10	53	3200	●	●	●	○
TFV15S121K	75	100	108	132	200	75	5	10	64	2700	●	●	●	○
TFV15S151K	95	125	135	165	250	75	5	10	85	2200	●	●	●	○
TFV15S181K	115	150	162	198	300	75	5	10	96	1800	●	●	●	○
TFV15S201K	130	170	180	220	340	75	5	10	102	1600	●	●	●	○
TFV15S221K	140	180	198	242	360	75	5	10	125	1450	●	●	●	○
TFV15S241K	150	200	216	264	395	75	5	10	134	1350	●	●	●	○
TFV15S271K	175	225	243	297	455	75	5	10	158	1200	●	●	●	○
TFV15S301K	190	250	270	330	500	75	5	10	173	1050	●	●	●	○
TFV15S331K	210	275	297	363	550	75	5	10	185	1000	●	●	●	○
TFV15S361K	230	300	324	396	595	75	5	10	208	900	●	●	●	○
TFV15S391K	250	320	351	429	650	75	5	10	224	800	●	●	●	○
TFV15S431K	275	350	387	473	710	75	5	10	248	750	●	●	●	○
TFV15S471K	300	385	423	517	775	75	5	10	280	680	●	●	●	○
TFV15S511K	320	415	459	561	845	75	5	10	300	630	●	●	●	○
TFV15S561K	350	460	504	616	925	75	5	10	310	580	●	●	●	○
TFV15S621K	385	505	558	682	1025	75	5	10	310	530	●	●	●	○
TFV15S681K	420	560	612	748	1120	75	5	10	320	500	●	●	●	○
TFV15S751K	460	615	675	825	1240	75	5	10	335	430	●	●	●	○
TFV15S821K	510	670	738	902	1355	75	5	10	350	400	●	●	●	○

●: Approved      ○: Unauthorized

Specification

Model	Limited Current	Rated Function Temp.	Fuse Temp. (°C)	Holding Temp. (°C)	Rated Voltage	
		$T_f$			AC	DC
	(A)	(°C)	(V)	(V)		
TFV15S820K	5	145	140±2	118	250	50
TFV15S101K	5	145	140±2	118	250	50
TFV15S118K	5	145	140±2	118	250	50
TFV15S151K	5	145	140±2	118	250	50
TFV15S181K	5	145	140±2	118	250	50
TFV15S201K	5	145	140±2	118	250	50
TFV15S221K	5	145	140±2	118	250	50
TFV15S241K	5	145	140±2	118	250	50
TFV15S271K	5	145	140±2	118	250	50
TFV15S301K	5	145	140±2	118	250	50
TFV15S331K	5	145	140±2	118	250	50
TFV15S361K	5	145	140±2	118	250	50
TFV15S391K	5	145	140±2	118	250	50
TFV15S431K	5	145	140±2	118	250	50
TFV15S471K	5	145	140±2	118	250	50
TFV15S511K	5	145	140±2	118	250	50
TFV15S561K	5	145	140±2	118	250	50
TFV15S621K	5	145	140±2	118	250	50
TFV15S681K	5	145	140±2	118	250	50
TFV15S751K	5	145	140±2	118	250	50
TFV15S821K	5	145	140±2	118	250	50

Note:

The above data is for reference only.

TFV

TFV



**Performance Curve (For reference only )**

- Max. Peak Current Derating Curves

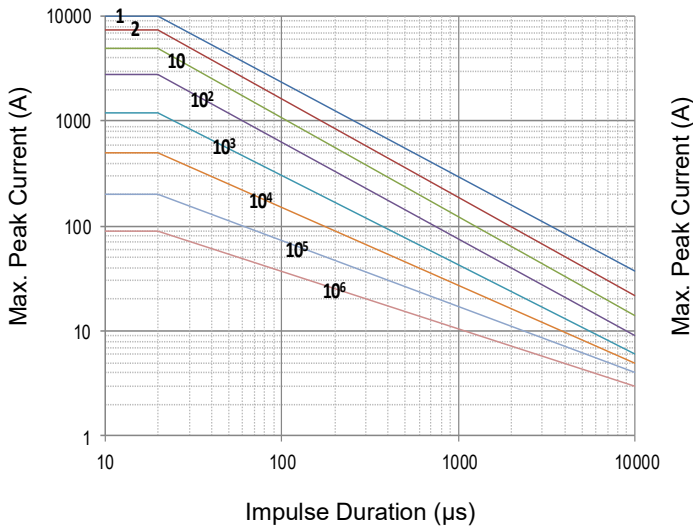

TFV15S820K to TFV15S821K

Note: 1, 2, 10, 10<sup>2</sup>, 10<sup>3</sup>, 10<sup>4</sup>, 10<sup>5</sup>, 10<sup>6</sup> Stand for Repetitions.

- Voltage-Current Characteristic Curves

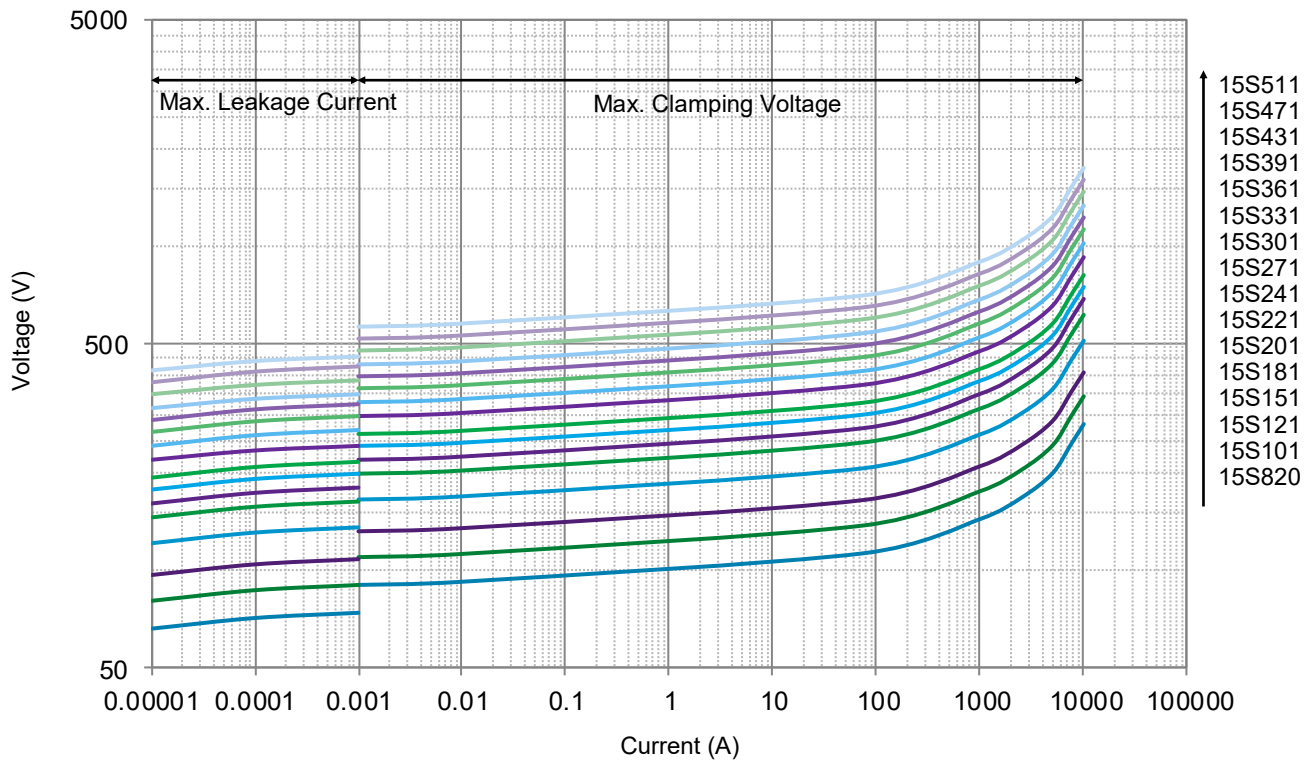

- Voltage-Current Characteristic Curves

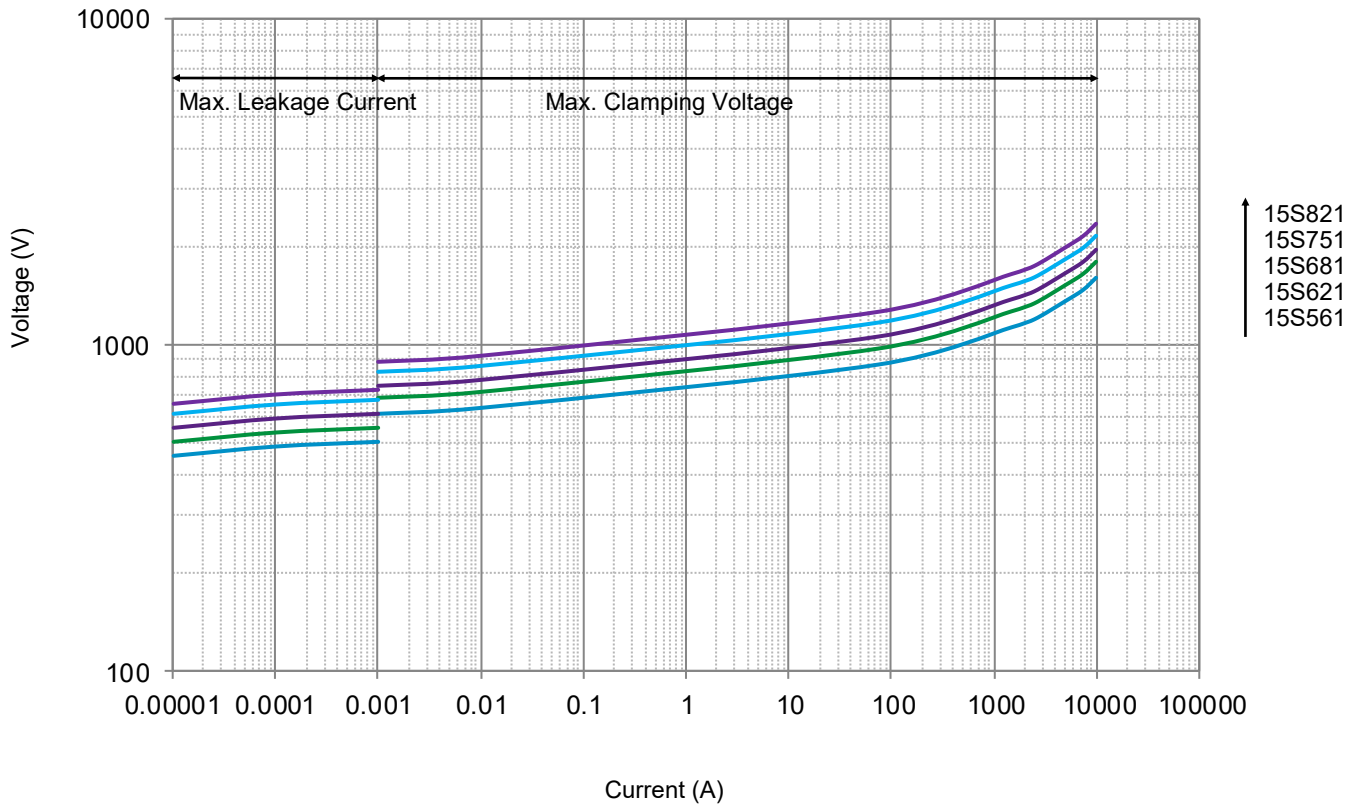

TFV

TFV

## Soldering Parameters

### Wave Soldering Parameters

The wave soldering parameters are for reference only. When MOV is for practice use, some related validation is recommended.

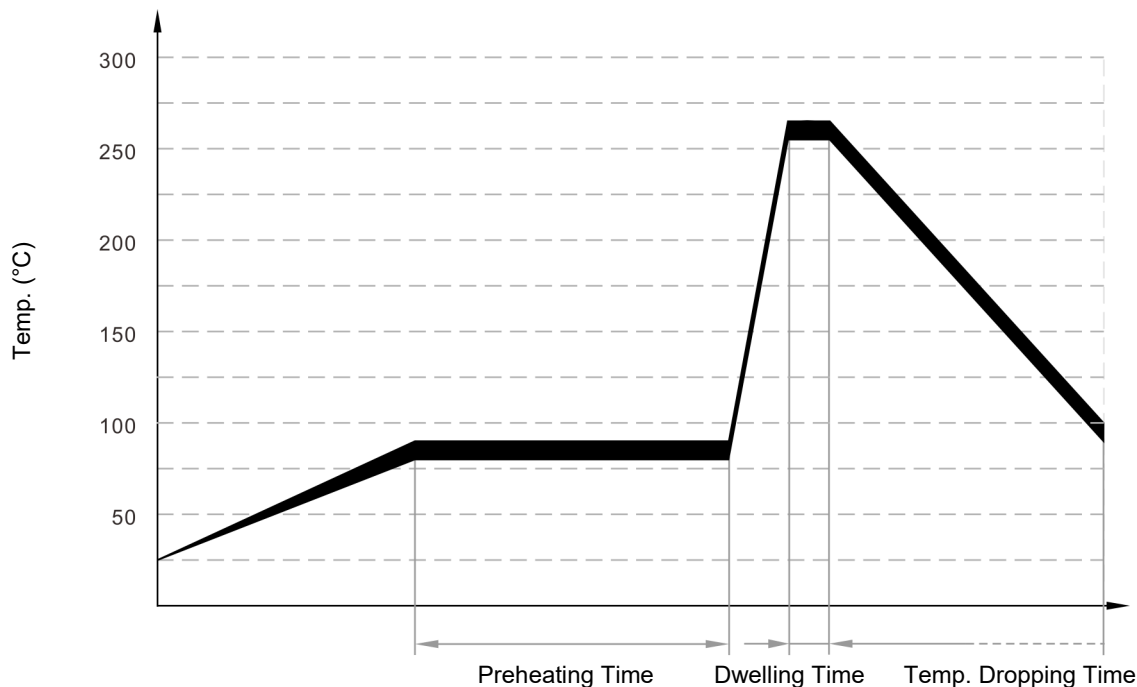

Wave Soldering Curve

Item	Temp. (°C)	Time (s)
Preheating	80 to 90	60 to 150
Dwelling	260±5	2 to 4
Cooling Time	≤80	10

### Recommended Hand-Soldering Parameters

Item	Condition
Temp. of Solder Head	350 °C (max.)
Soldering Time	4 seconds (max.)
Distance between Soldering Point and Coating	2 mm (min.)

## Packaging Information

- Bulk Packaging (Code: BUL)
- Bulk Packaging Dimensions & Quantity

Series	Nominal Varistor Voltage	PE Bag	Box	Carton	Gross Weight / Carton
	(V)	(PCS)	(PCS)	(PCS)	(kg)±10%
15S	820 ~ 361	200	400	2400	5 ~ 10
	391 ~ 561	150	300	1800	7 ~ 11
	621 ~ 821	100	200	1200	6 ~ 10

Note:  
Other lead length packaging information, please contact SETsafe | SETfuse.

All Dimensions in mm

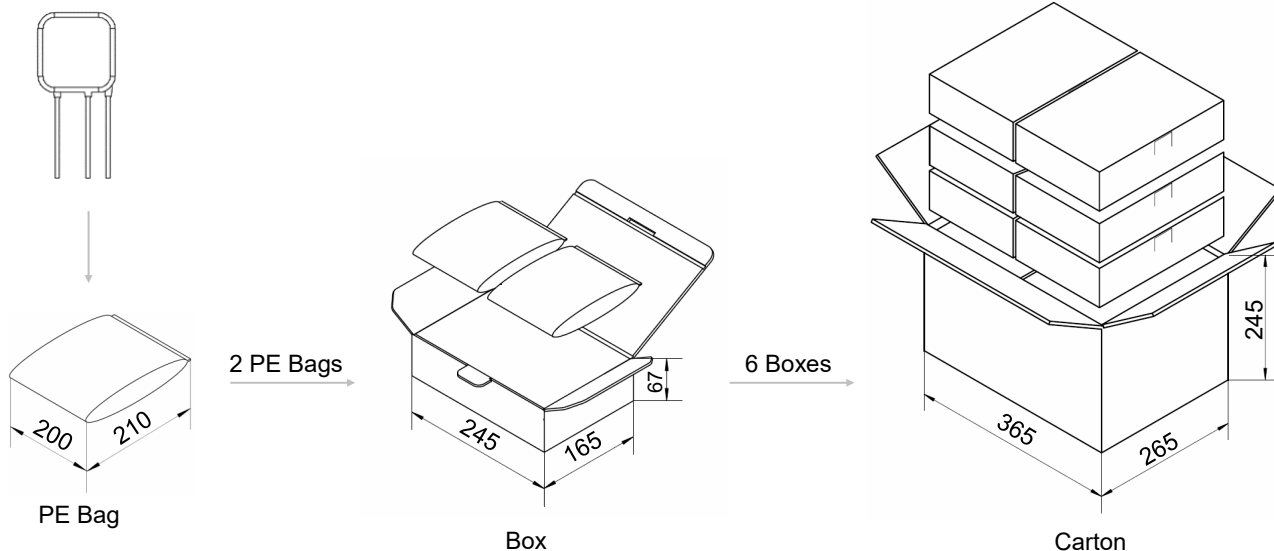

## Attention

### Usage

1. Please do not apply severe vibration, shock or pressure to avoid surface resin or element cracking.
2. Please fix lead wires when bending or cutting. The distance between the bending point and the sealing of MOV shall be greater than 2mm.
3. In order to reduce the surface temperature rise, adding heat insulated shroud is recommended before wave soldering.
4. This curve is for reference only. Please confirm before production to avoid damaging the integrated Thermal Fuse.

### Replacement

1. If varistor is visually damaged, please replace it.
2. Varistor is a non-repairable product. For safety sake, please use equivalent varistor for replacement.

### Storage

1. Storage Temp. Range: (-40 to +125) °C
2. Relative Humidity : ≤75% RH
3. Do not store the MOV at the high temp., high humidity or corrosive gas environment, to avoid influencing the solder-ability of the lead wires, the product shall be used up within 1 year after receiving the goods.

### Environmental Conditions

1. Varistor should not be exposed to the open air, nor direct sunshine.
2. Varistor should avoid rain, water vapor or other condition of high temp. and high humidity.
3. Varistor should avoid sand dust, salt spray, or other harmful gases.

### Max. Typical Capacitance of Varistor

The typical capacitance of varistor is listed in the specifications. Designers may refer to it when designing MOV in high frequency circuit.

## Installation

### Mechanical Stress

Do not knock MOV when installing, to avoid mechanical damage.

Please do not apply severe vibration, shock or pressure to MOV, to avoid surface resin or element cracking.

## Application Examples

The application examples below show how the indicator lead on the TFV can be used to indicate that the thermal element has been opened. This signifies that the circuit is no longer protected from transients by the MOV.

1. In this case, the LED is normally on, and is off when the thermal element opens.
2. This circuit utilizes an optocoupler to provide galvanic isolations between the TFV varistor and the indicating or alarm circuitry.

